

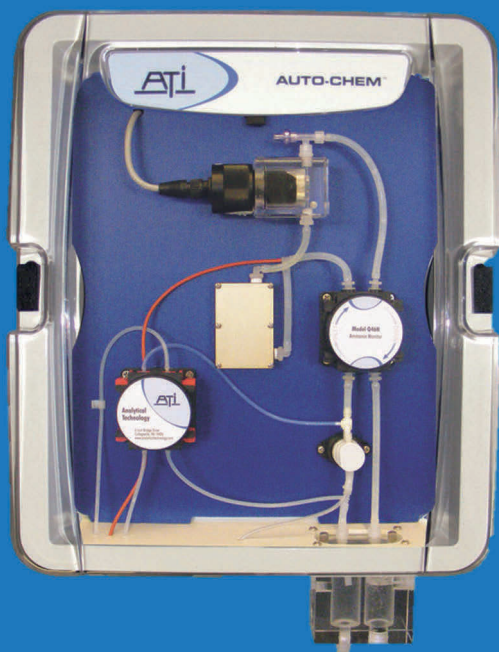

## O & M Manual



### Model Q46TN Auto-Chem Total Ammonia

#### Home Office

Analytical Technology, Inc.  
6 Iron Bridge Drive  
Collegeville, PA 19426  
Phone: 800-959-0299  
610-917-0991  
Fax: 610-917-0992  
Email: [sales@analyticaltechnology.com](mailto:sales@analyticaltechnology.com)

#### European Office

ATI (UK) Limited  
Unit 1 & 2 Gatehead Business Park  
Delph New Road, Delph  
Saddleworth OL3 5DE  
Phone: +44 (0)1457-873-318  
Fax: + 44 (0)1457-874-468  
Email: [sales@atiuk.com](mailto:sales@atiuk.com)

# Table of Contents

---

<b>PART 1 - INTRODUCTION.....</b>	<b>4</b>	<b>PART 6 – CALIBRATION.....</b>	<b>46</b>
1.1 General.....	4	6.1 Calibration .....	46
1.2 Q46TN System Specifications.....	6	6.11 Total Ammonia Zero .....	46
1.3 Q46TN Performance Specifications .....	7	6.12 Total Ammonia Span.....	47
<b>PART 2 – MECHANICAL INSTALLATION.....</b>	<b>8</b>	6.2 Temperature Calibration.....	48
2.1 General.....	8	<b>PART 7 – PID CONTROLLER DETAILS.....</b>	<b>49</b>
2.2 Wall Mount Bracket .....	9	7.1 PID Description .....	49
2.3 Panel Mount, AC Powered Monitor .....	11	7.2 PID Algorithm .....	49
2.4 Auto-Chem Mounting.....	12	7.3 Classical PID Tuning .....	51
2.5 Reagent Bottle Bracket and Pickup Assembly.....	14	7.4 Manual PID Override Control .....	51
2.6 Inlet and Drain Connections .....	15	7.5 Common PID Pitfalls.....	51
<b>PART 3 – ELECTRICAL INSTALLATION.....</b>	<b>16</b>	<b>PART 8 – SYSTEM MAINTENANCE .....</b>	<b>53</b>
3.1 General.....	16	8.1 General.....	53
3.2 Q46N Digital Input or Output.....	18	8.2 Analyzer Maintenance .....	53
3.3 Q46 Sensor Wiring .....	19	8.3 Sensor Maintenance.....	53
3.4 Relay Wiring.....	20	8.4 Sample Pump Tube Replacement .....	53
3.5 Auto-Chem Power Panel .....	21	8.5 Reagent Pump Tube Replacement.....	54
3.6 Auto-Chem to Q46 Power Interconnect ..	23	<b>PART 9 – TROUBLESHOOTING .....</b>	<b>55</b>
<b>PART 4 – AUTO-CHEM STARTUP.....</b>	<b>24</b>	9.1 General.....	55
4.1 General.....	24	9.2 External Sources of Problems.....	55
4.2 Sensor Preparation .....	24	9.3 Analyzer Tests .....	56
4.3 Reagent Preparation.....	25	9.4 Display Messages .....	57
4.4 Reagent Pump Priming .....	27	<b>SPARE PARTS.....</b>	<b>58</b>
4.5 Sensor Installation .....	27		
4.6 Operation .....	28		
4.7 Temperature Adjustment .....	29		
4.8 Response Verification System.....	29		
<b>PART 5 – CONFIGURATION.....</b>	<b>31</b>		
5.1 User Interface .....	31		
5.11 Keys.....	32		
5.12 Display.....	32		
5.2 Software.....	33		
5.21 Software Navigation .....	34		
5.22 Measure Menu [MEASURE].....	36		
5.23 Calibration Menu [CAL] .....	37		
5.24 Configuration Menu [CONFIG] .....	37		
5.25 Control Menu [CONTROL] .....	39		
5.26 Diagnostics Menu [DIAG].....	43		

## Table of Figures

---

FIGURE 1 – TYPICAL FREE AMMONIA MONITORING SYSTEM .....	5
FIGURE 2 - Q46 ENCLOSURE DIMENSIONS.....	8
FIGURE 3 - WALL OR PIPE MOUNT BRACKET .....	9
FIGURE 4 - WALL MOUNTING DIAGRAM.....	10
FIGURE 5 - PIPE MOUNTING DIAGRAM .....	10
FIGURE 6 - PANEL MOUNT CUT-OUT .....	11
FIGURE 7 – AUTO-CHEM ENCLOSURE MOUNTING FEET.....	12
FIGURE 8 – AUTO-CHEM DIMENSIONAL DRAWING .....	13
FIGURE 9 - BOTTLE BRACKET & REAGENT FEED ASSEMBLY .....	14
FIGURE 10 - LINE POWER CONNECTION .....	17
FIGURE 11 – DIGITAL INPUT OR OUTPUT CONNECTION.....	18
FIGURE 12 - SENSOR AND CONTROL CONNECTION .....	19
FIGURE 13 - RELAY CONTACTS.....	20
FIGURE 14 – AUTO-CHEM CONNECTION PANEL .....	21
FIGURE 15 - AUTO-CHEM INTERNAL WIRING .....	22
FIGURE 16 - ANALYZER CONNECTION FROM AUTOCHEM.....	23
FIGURE 17 - SENSOR EXPLODED VIEW.....	24
FIGURE 18 – AUTO-CHEM PANEL COMPONENTS.....	28
FIGURE 19 – RESPONSE VERIFICATION SYSTEM DIAGRAM .....	30
FIGURE 20 - USER INTERFACE .....	31
FIGURE 21 - SOFTWARE MAP.....	35
FIGURE 22 - CONTROL RELAY EXAMPLE.....	41
FIGURE 23 - ALARM RELAY EXAMPLE .....	42
FIGURE 24 - Q46 ISA PID EQUATION.....	49
FIGURE 25 – SAMPLE PUMP EXPLODED VIEW.....	54
FIGURE 26 - Q46 DISPLAY MESSAGES .....	57

# Part 1 - Introduction

---

## 1.1 General

The Q46TN Total Ammonia system is designed for the continuous measurement of ammonia in potable water or wastewater effluent. It is intended for monitoring low levels of ammonia and provide very high sensitivity for measuring down to less than 0.1 PPM. The full scale operating range of the system is 0-5.00 PPM. The display is capable of values as high as 20.00 PPM, but the instrument should not be used for monitoring water with ammonia concentration higher than 5 PPM. The analog output signal may be spanned for smaller ranges, with 0-1 PPM being a common range. Q6TN chemistry modules are designed to operate on sample temperatures from 5-40°C. Because water is flowing through the chemistry module at a low rate, this unit cannot be exposed to temperatures below 0°C.

The Q46TN Ammonia System uses a unique chemistry that converts ammonia in solution to a stable monochloramine compound equivalent in concentration to the original ammonia level.

Sample and drain connections are made to an inlet overflow assembly located under the chemistry module enclosure. An adapter for ¼" ID tubing is supplied for the inlet and a ½" ID hose barb is provided for the drain connection.

The Q46TN Ammonia system consists of two separate parts, a wall mounted electronic unit and an Auto-Chem chemistry system. AC power is required for both the monitor and chemistry system. Power may be brought to each unit separately, or may be connected to the chemistry module only, with a short power cable connecting the monitor to terminals in the chemistry unit. A 10 ft. length of 9-conductor shielded cable connects the sensor in the chemistry module to the monitor.

Three separate reagents are required for operation. Reagent filter assemblies are included for each and must be used to ensure that no obstructions occur in the reagent tubing. Four feet of pickup tubing is supplied for each reagent. Reagent pickup assemblies, sensor membranes and electrolyte, spare parts, and a copy of the manual are packed inside the chemistry module for shipment.

For applications where the ammonia is normally zero, the Q46TN provides an automated verification system that tests the system with an ammonia standard at user defined intervals. The test function can also be triggered remotely if required.

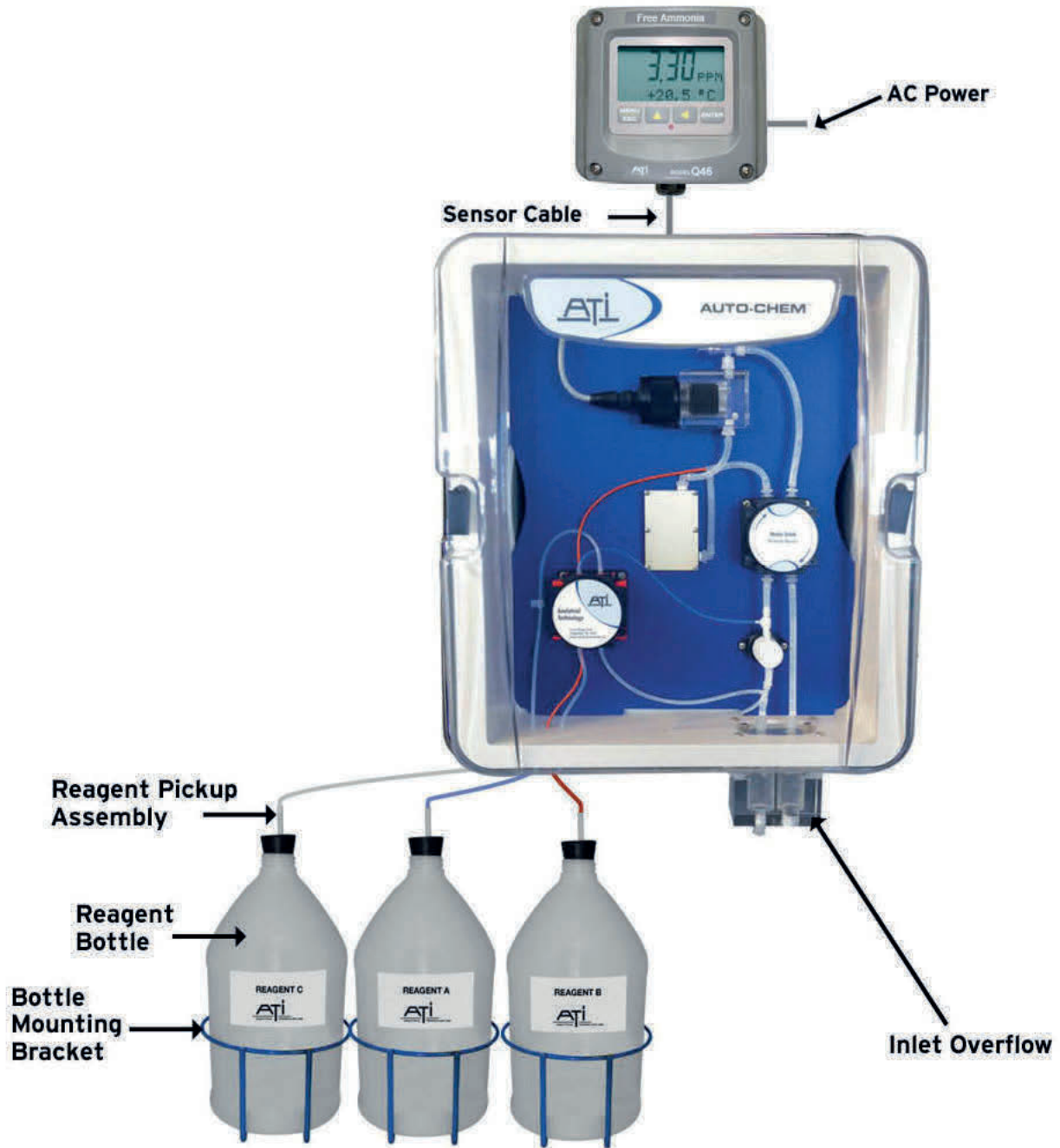

Figure 1 – Typical Ammonia Monitoring System

## 1.2 Q46TN System Specifications

<b>Displayed Parameters</b>	Total Ammonia, 0.00 ppm to 5.00 ppm Sensor temperature, -10.0 to 55.0 °C (23 to 131 °F) Sensor Current, 0.0–999.9 nA, 0.000 to 99.99 uA Sensor slope/offset Model number and software version PID Controller Status (if enabled)
<b>Display Range</b>	0-20.00 PPM or mg/l
<b>Display</b>	0.75" (19.1 mm) high 4-digit main display with sign 12-digit secondary display, 0.3" (7.6 mm) 5x7 dot matrix. Integral LED back-light for visibility in the dark.
<b>Ambient Temperature</b>	Analyzer Service, 5 to 40°C (41 to 104°F) Storage, -5 to 70°C (-22 to 158°F)
<b>Ambient Humidity</b>	0 to 95%, non-condensing.
<b>EMI/RFI Influence</b>	Designed to EN 61326-1
<b>Output Isolation</b>	600 V galvanic isolation
<b>Filter</b>	Adjustable 0-9.9 minutes additional damping to 90% step input
<b>Sensor</b>	Polarographic membraned ammonia sensor
<b>Sensor Materials</b>	PVC & 316 Stainless Steel
<b>Interconnect Cable</b>	10 ft. (6.15 meter) standard
<b>Q46 Power:</b>	100-240 VAC ±10%, 50/60 Hz
<b>Auto-Chem Power:</b>	115 or 230 VAC, 50/60 Hz
<b>Q46 Enclosure:</b>	NEMA 4X, IP66, polycarbonate, stainless steel hardware HWD: 4.9" (124 mm) x 4.9" (124 mm) x 5.5" (139 mm) Flammability rating: UL 94 V-0
<b>Auto-Chem Enclosure:</b>	NEMA 1, IP11, Kydex with Polycarbonate Clear Lid HWD: 4.9" (124 mm) x 4.9" (124 mm) x 5.5" (139 mm) Flammability rating: UL 94 V-0
<b>Mounting Options</b>	Wall mount bracket standard. Panel mount adapter optional for Q46 Only
<b>Relays, Electromechanical</b>	Three SPDT, 6 amp @ 250 VAC, 5 amp @ 24 VDC contacts. Software selection for setpoint, phase, delay, deadband, hi-lo alarm, and failsafe. A-B indicators on main LCD.

<b>Analog Outputs</b>	Two 4-20 mA outputs. Output one programmable for PPM Ammonia or PID. Output 2 programmable for Ammonia or temperature. Maximum load 500 Ohms for each output. Outputs ground isolated and isolated from each other.
<b>Digital Communications</b>	Options for Profibus-DP, Modbus-RTU, Modbus-TCP/IP, or Ethernet-IP
<b>Sample Flowrate</b>	5 GPH Minimum (0.33 LPM) 15 GPH Maximum (1 LPM)
<b>Weight</b>	20 lbs. (9 Kg.)

### 1.3 Q46TN Performance Specifications

<b>Accuracy</b>	$\pm 0.05$ PPM below 2 PPM, $\pm 0.1$ PPM above 2 PPM
<b>Repeatability</b>	$\pm 0.02$ PPM or 1% of selected range
<b>Sensitivity</b>	0.01 PPM
<b>Non-linearity</b>	0.5% of selected range
<b>Warm-up Time</b>	3 seconds to rated performance (electronics only) Sensors require 1 hour stabilization at start-up
<b>Supply Voltage Effects</b>	$\pm 0.05\%$ span
<b>Instrument Response Time</b>	120 seconds to 90% of step input at lowest damping



Equipment bearing this marking may not be discarded by traditional methods in the European community after August 12 2005 per EU Directive 2002/96/EC. End users must return old equipment to the manufacturer for proper disposal.

## Part 2 – Mechanical Installation

### 2.1 General

Mechanical installation of a Q46TN Ammonia system involves mounting of the Q46 electronic assembly, mounting of the Auto-Chem chemistry module, and mounting of the reagent bottle brackets.

Proper planning of the installation will benefit operation and maintenance of the system. Here are a few considerations

1. Locate the Q46 electronics where personnel can easily access the front panel control keys. Calibration of the system requires access to these controls.
2. Locate the chemistry module high enough above the floor so that servicing of the pumps is not difficult. Pump tubing must be replaced every 6 months so access to the chemistry system is required.
3. Do not mount the reagent bottle closer than about 18" from the bottom of the chemistry module. Mounting too close will make removal of the bottle difficult.
4. Water sample and drain lines connect to an inlet overflow assembly at the bottom of the chemistry module. Locate the chemistry module so that the drain line is short and can flow freely.

The Q46 monitor is wall mounted using a PVC plate supplied with the unit. The bracket kit contains 4 screws for attaching the plate to the back of the enclosure. A paper template is supplied to ease of locating anchors in the wall.

The Auto-Chem chemistry module is supplied with 4 stainless steel mounting feet and 8 attachment screws (10-32 x 1/4" long). Inserts in the back of the enclosure provide for attachment of the mounting feet.

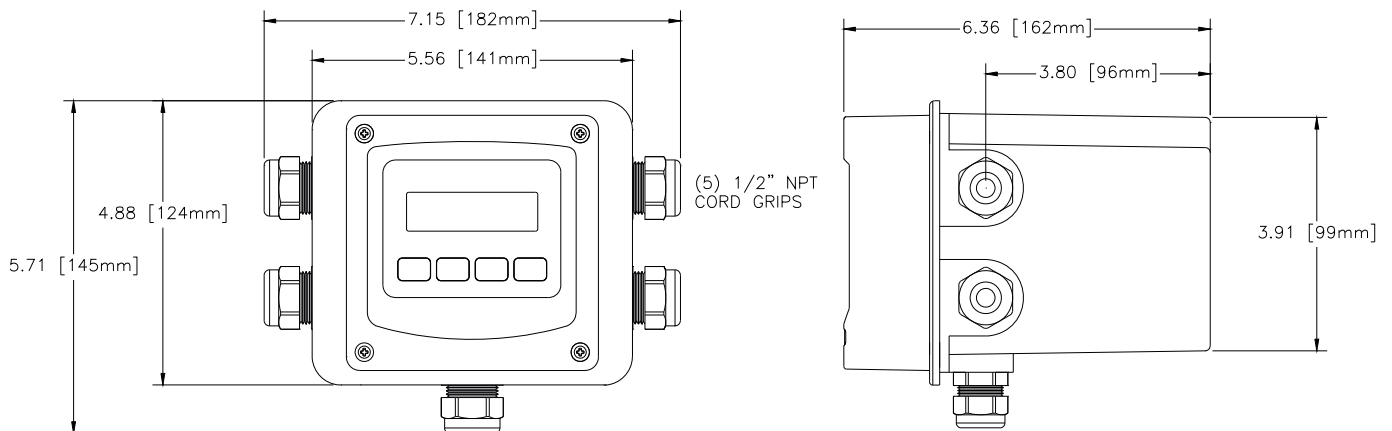

**Figure 2 - Q46 Enclosure Dimensions**



## 2.2 Wall Mount Bracket

A PVC mounting bracket with attachment screws is supplied with each transmitter (see

Figure 3 for dimensions). The multi-purpose bracket is attached to the rear of the enclosure using the four flat head screws. The instrument is then attached to the wall using the four outer mounting holes in the bracket. These holes are slotted to accommodate two sizes of u-bolt that may be used to pipe mount the unit. Slots will accommodate u-bolts designed for 1½" or 2" pipe. The actual center to center dimensions for the u-bolts are shown in the drawing. Note that these slots are for u-bolts with ¼-20 threads. The 1½" pipe u-bolt (2" I.D. clearance) is available from

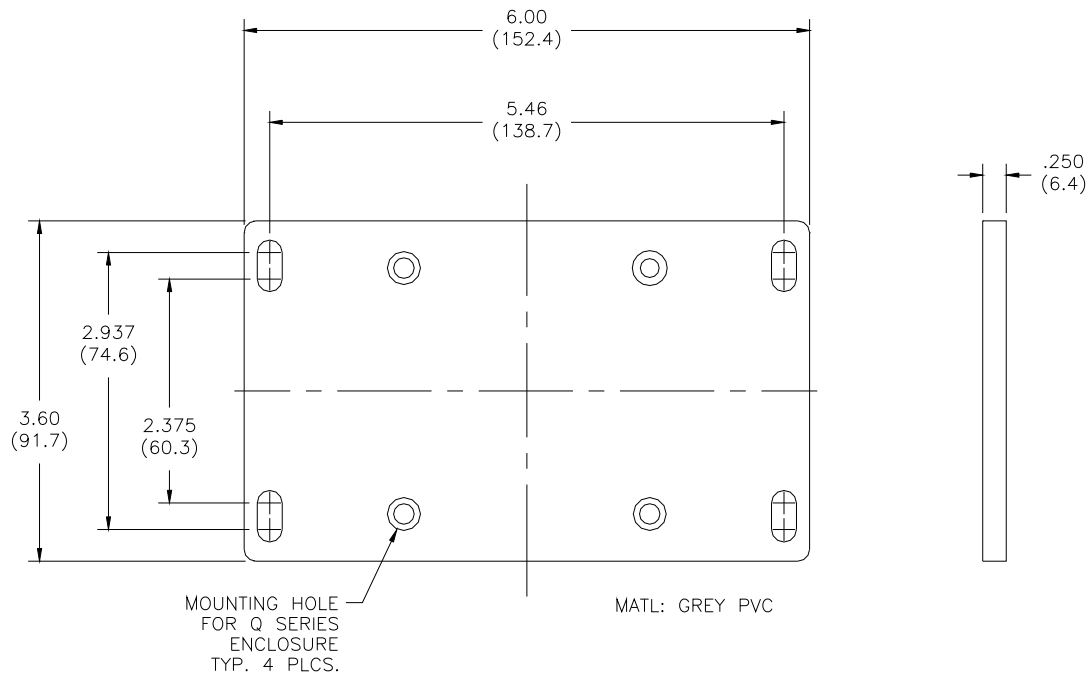

ATI in type 304 stainless steel under part number 47-0005

**Figure 3 - Wall or Pipe mount Bracket**

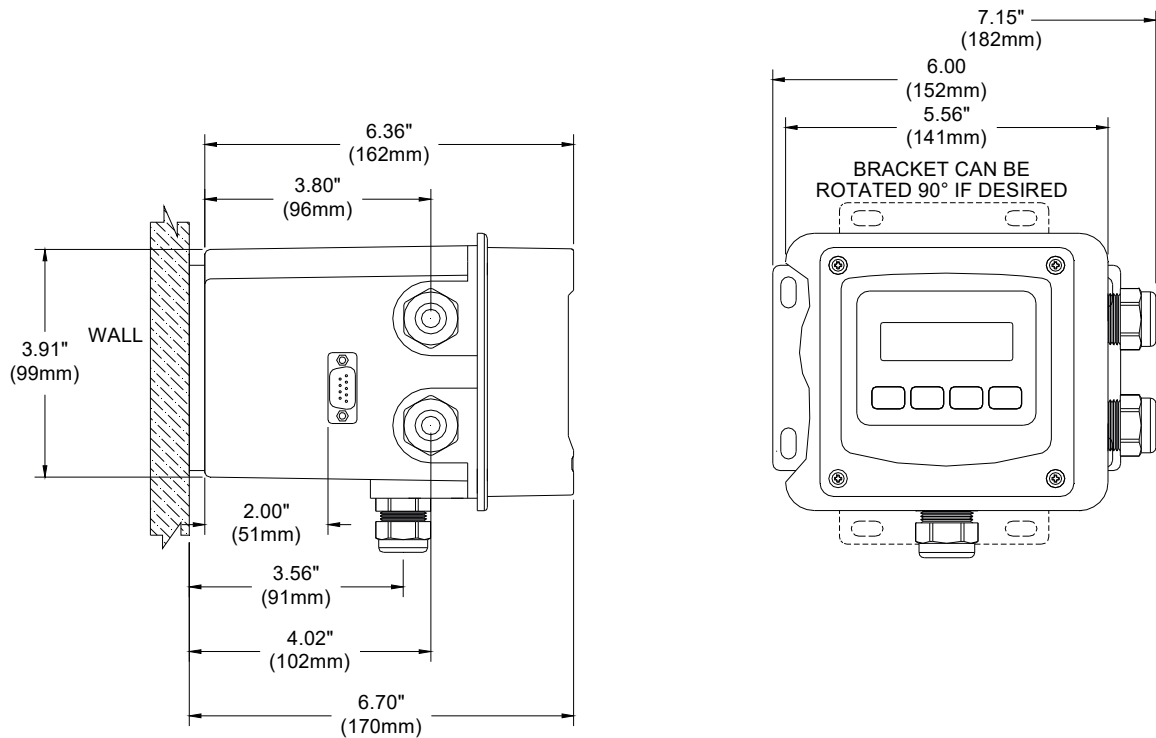

Figure 4 - Wall Mounting Diagram

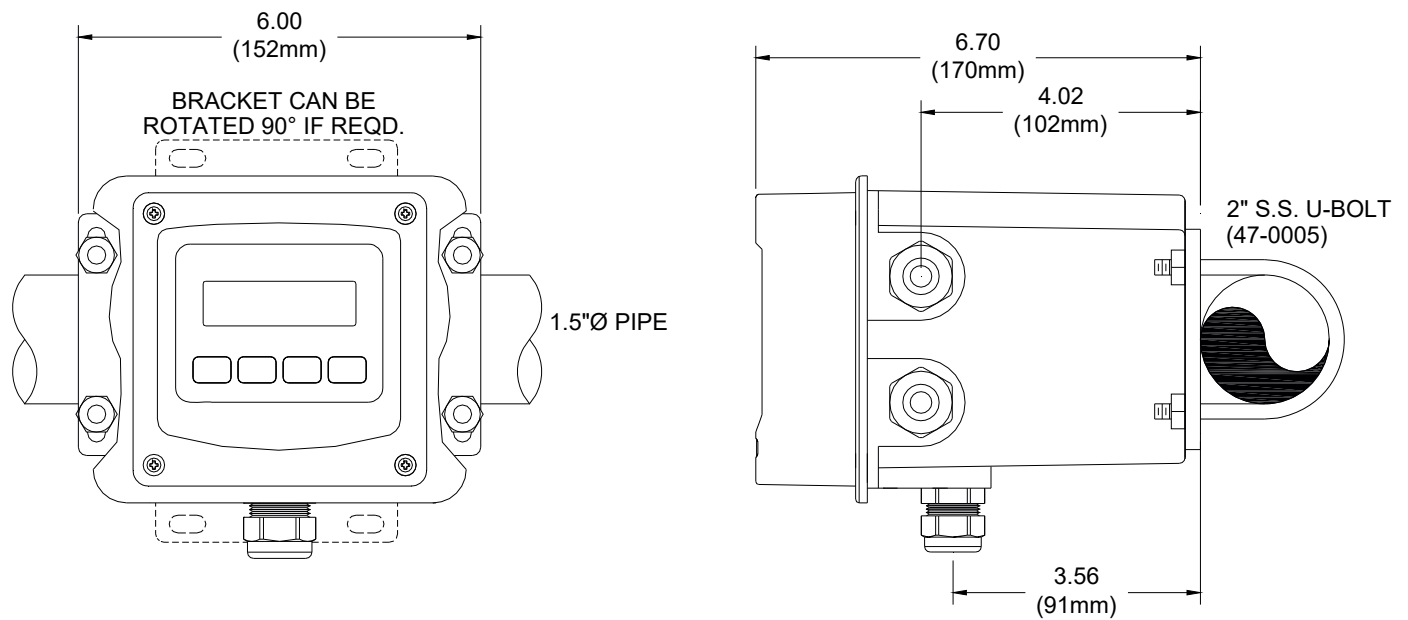

Figure 5 - Pipe Mounting Diagram

### 2.3 Panel Mount, AC Powered Monitor

Panel mounting of the Q46 monitor uses the panel mounting flange molded into the rear section of the enclosure. Figure 6 provides dimensions for the panel cutout required for mounting.

The panel bracket kit must be ordered separately (part number 05-0094). This kit contains a metal retainer bracket that attaches to the rear of the enclosure, 4 screws for attachment of this bracket, and a sealing gasket to ensure that the panel mounted monitor provides a water tight seal when mounted to a panel.

The sealing gasket must first be attached to the enclosure. The gasket contains an adhesive on one side so that it remains in place on the enclosure. Remove the protective paper from the adhesive side of the gasket and slide the gasket over the back of the enclosure so that the adhesive side lines up with the back of the enclosure flange. Once in place, mount the monitor in the panel.

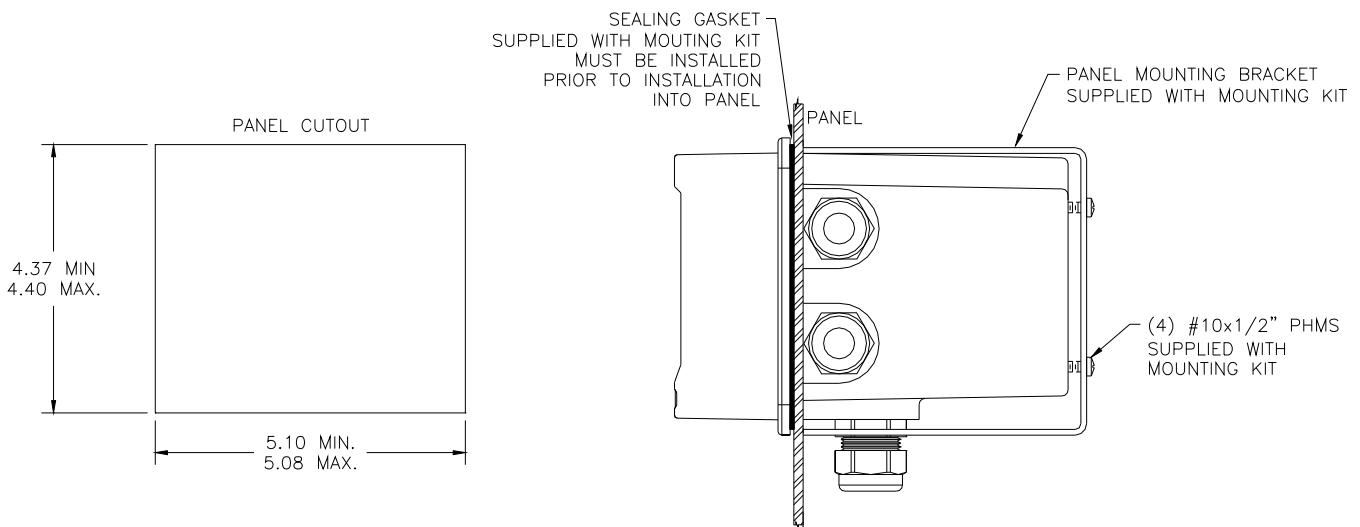

**Figure 6 - Panel Mount Cut-Out**

## 2.4 Auto-Chem Mounting

The chemistry module should be mounted on a wall or flat plate. A template is provided for marking the location of mounting screws. The stainless steel mounting feet must first be screwed to the back of the enclosure using the screws supplied.

Tape the mounting template to the wall and mark the 4 screw locations. Mount any wall anchors first and then screw in the two bottom mounting screws about half way. Place the two bottom mounting feet of the enclosure on to the screws and tilt the enclosure into place. Install the two top screws to secure the enclosure and then tighten the bottom screws.



**Figure 7 – Auto-Chem Enclosure Mounting Feet**

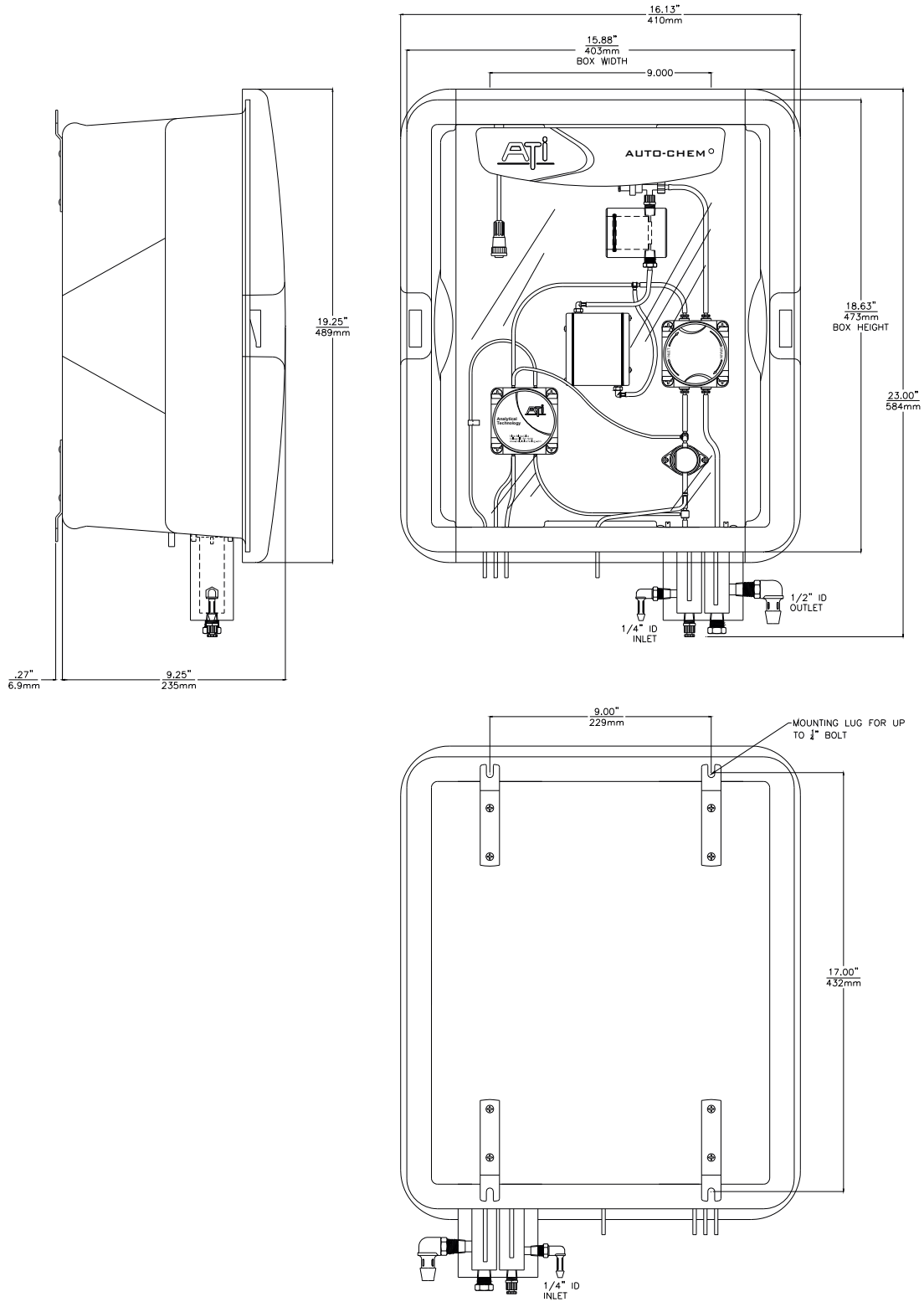
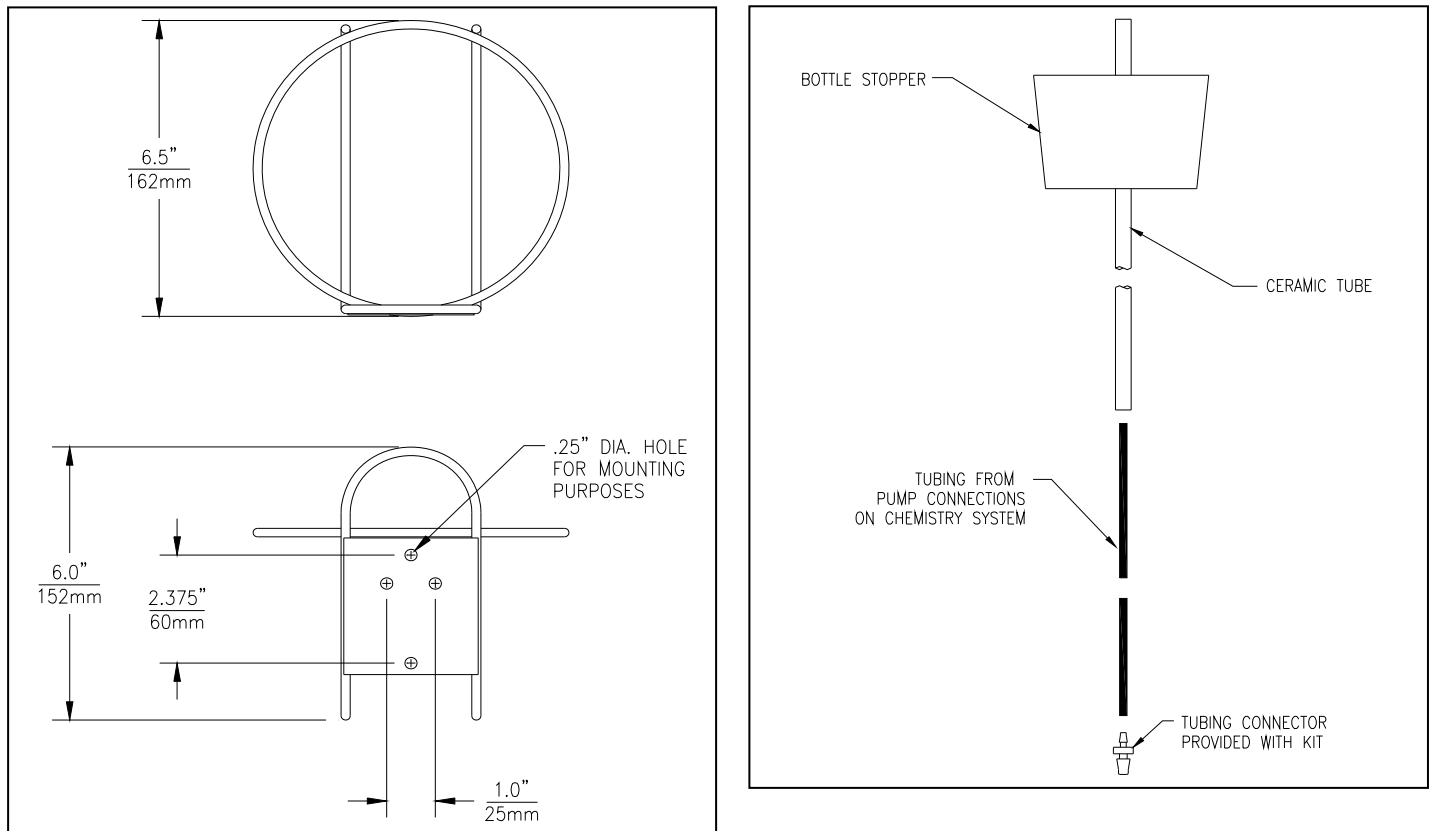

Figure 8 – Auto-Chem Dimensional Drawing

## 2.5 Reagent Bottle Bracket and Pickup Assembly

The Auto-Chem system requires approximately 1 gallon of reagent every 25 days. A one gallon bottle holder is supplied and mounts to the wall. It is sufficient to mount the bracket using only the upper two mounting holes. A standards pick-up assembly (03-0450) is supplied that fits into the mouth of the bottle. Attach the tubing connector to the tubing after you have slid tubing from chemistry system through the ceramic tube coming through bottle stopper. This will keep the tubing from floating to the top of the liquid.



**Figure 9 - Bottle Bracket & Reagent Feed Assembly**

## 2.6 Inlet and Drain Connections

**Note:** To avoid shipping damage, the inlet assembly is shipped separately and must be installed on the bottom of the chemistry module after the enclosure has been mounted to the wall. The inlet assembly is supplied with 4 mounting screws for attachment to the enclosure. The photo below shows the inlet assembly attached to the enclosure.

The sample inlet is connected to the inlet overflow assembly mounted on the bottom of the chemistry module. For convenience, a 10 ft. piece of  $\frac{1}{4}$ " I.D. PVC tubing is supplied. This tubing mates with the inlet hose barb located on the bottom of the inlet assembly.

The drain connection is a  $\frac{1}{2}$ " I.D. hose barb on the bottom of the overflow assembly. A 5 ft. length of PVC drain tubing is also supplied. The drain should be a free flowing gravity drain. No backpressure is allowed on the drain line.

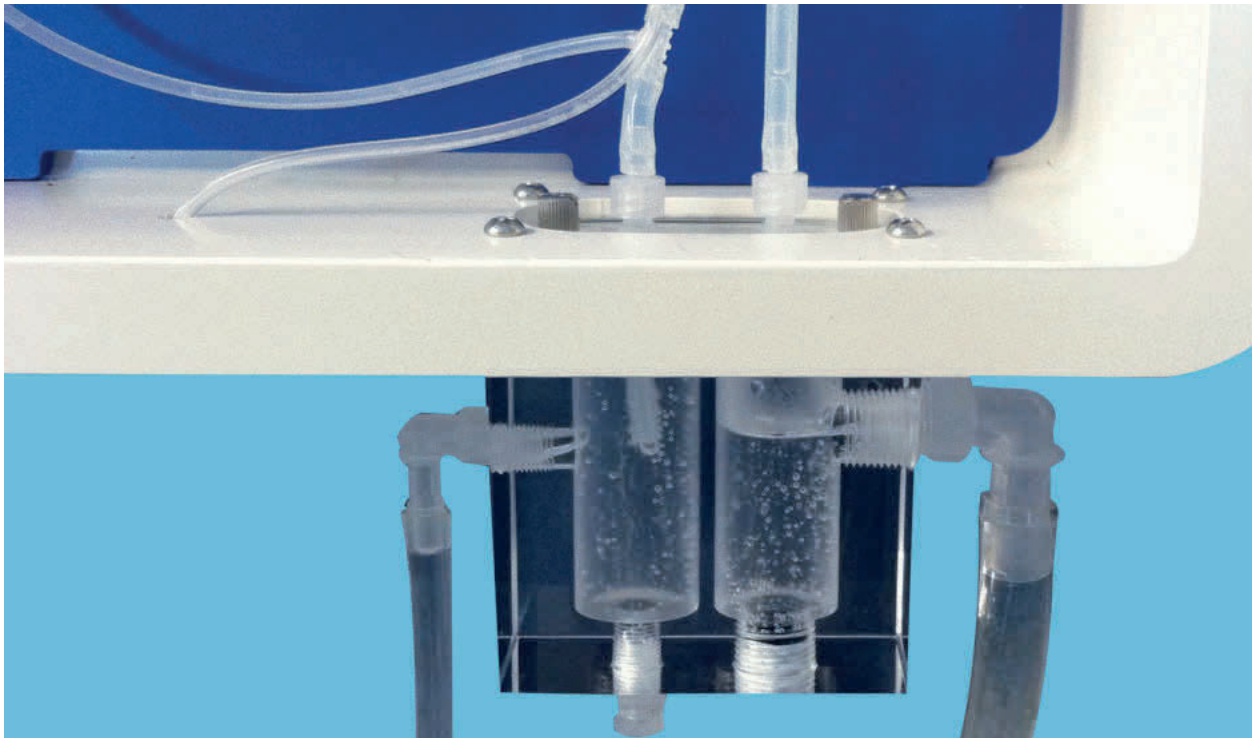

## Part 3 – Electrical Installation

---

### 3.1 General



The Q46 electronics contains a universal power supply operating on voltages between 90 and 265 VAC, 50/60 cycle. Auto-Chem Chemistry modules are not universal and must be ordered for operation from EITHER 115 VAC or 230 VAC. Please verify the type of unit before connecting any power. The Auto-Chem assembly contains two DIN rail mounted power supplies, one of which is AC power dependent. The 24 VAC supply located next to the AC power input terminals is the power supply that must be compatible with the installation site. If there is any question, remove the power supply from the DIN rail and check the label on the bottom of the supply. **Connection of 230 VAC power to a 115 VAC unit will result in damage to the power supply assembly.**

#### Important Notes:

1. Use wiring practices that conform to all national, state and local electrical codes. For proper safety as well as stable measuring performance, it is important that the earth ground connection be made to a solid ground point from terminal 12 (Figure 10).
2. Do NOT run sensor cables or instrument 4-20 mA output wiring in the same conduit that contains AC power wiring. AC power wiring should be run in a dedicated conduit to prevent electrical noise from coupling with the instrumentation signals.

Q46 electronic units are supplied with five ½" NPT ports, two on each side and one on the bottom. Red plugs are provided for each port. Five cord grips are supplied separately for use during installation. A cord grip should be installed in the bottom port for sealing the sensor cable connection to the Auto-Chem unit. AC power should enter through the lower right hand port as the AC terminals are closest to this entry.

#### WARNING

**Disconnect line power voltage BEFORE connecting line power wires to Terminal TB7 of the power supply. The power supply accepts only standard three-wire single phase power. The power supply is configured for 100-240 VAC ±10% operation.. Do NOT connect voltages other than the labeled requirement to the input.**

Connect HOT, NEUTRAL, and GROUND to the matching designations on terminal strip **TB7**.

The analog outputs from the system are present at terminals TB1 and TB2. The loop-load limitation in this configuration is 500 Ohms maximum for each output. Also note that these three outputs are completely isolated from each other to ensure that ground loops do not result from the connection of both outputs to the same device such as a PLC or DCS.

A ribbon cable connects the power supply assembly with the microprocessor assembly located in the front section of the enclosure. This cable can be disconnected from the front section during installation to facilitate wiring. The ribbon cable has a marking stripe on one edge that is used to indicate proper orientation.



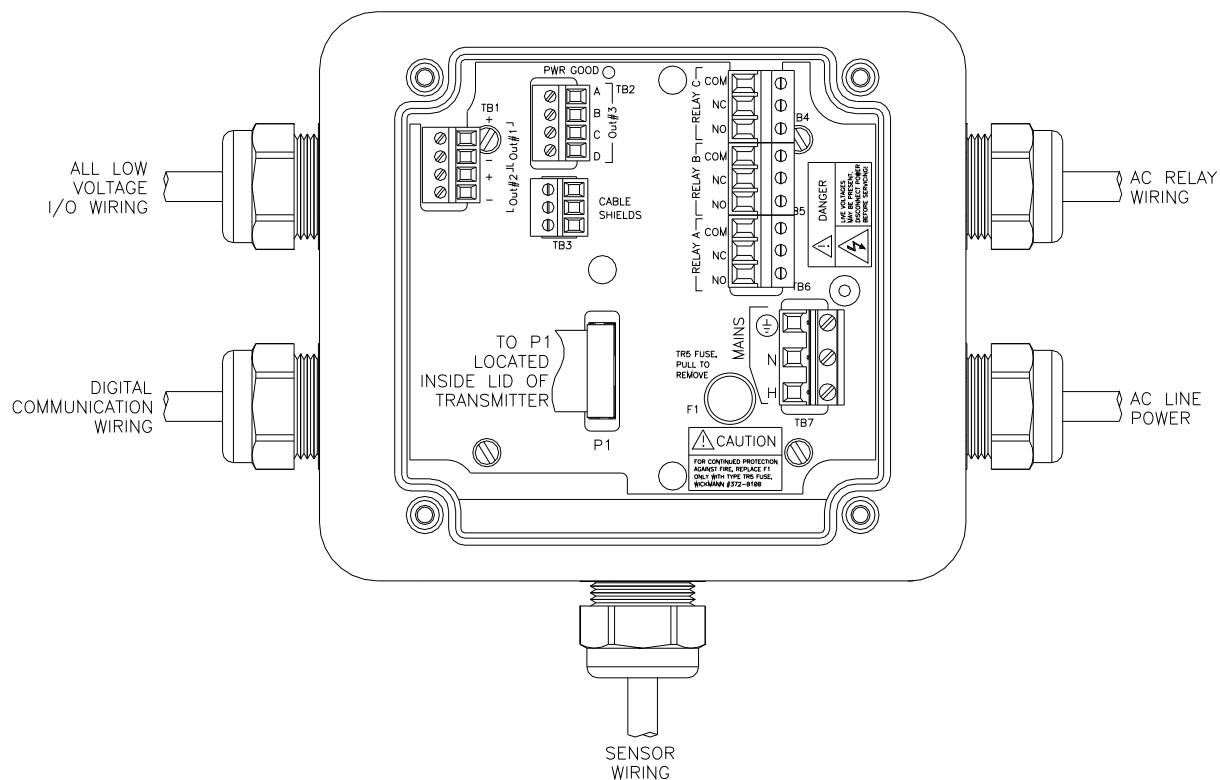

**Figure 10 - Line Power Connection**

The power strip, **TB5**, allows up to 12 AWG wire. A wire gauge of 16 AWG is recommended to allow for an easy pass-through into the M16 ports when wiring.

### 3.2 Q46N Digital Input or Output

The ammonia monitor contains an automatic testing function that is initiated with either an internal timer or a contact closure from another device. In one configuration (Timer T1), the system is activated by an internal timer. In this case, wiring terminals B&D of TB2 to digital input terminals of a PLC or DCS will allow remote indication that the system is in automatic test mode. In a second configuration (Timer T2), wiring a remote contact closure between terminals C&D of TB2 will allow remote activation of the test function.

Note that there is already one wire connection to terminal D. If an external connection is to be made, use 24 gauge wire for connections to B&D or C&D. Also note that any PLC or DCS input connected to B&D should be isolated and any remote input connected to C&D should be an isolated dry contact closure.

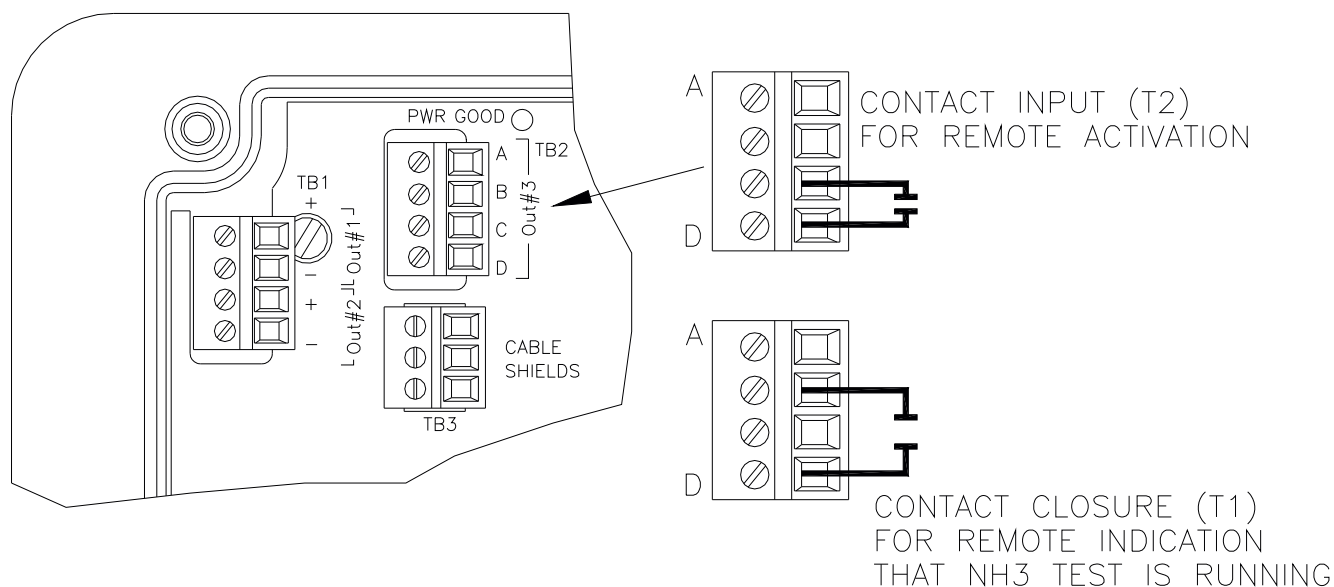

**Figure 11 – Digital Input or Output Connection**

### 3.3 Q46 Sensor Wiring

The interconnection between the Auto-Chem module and the Q46 electronics is a 9-conductor shielded cable. The chemistry module contains an amplifier module that converts the combined chlorine sensor signal into a 300-1200 mv. signal suitable for input to the Q46. Two conductors carry that signal and six of the nine conductors are used for direct wiring of the total chlorine sensor. One conductor in the cable is not used (brown). A 10 ft. length of 9-conductor cable is supplied but this cable may be shortened if desired. Removing excess cable makes for a cleaner installation and reduces the potential for RFI pickup in the interconnecting cable.

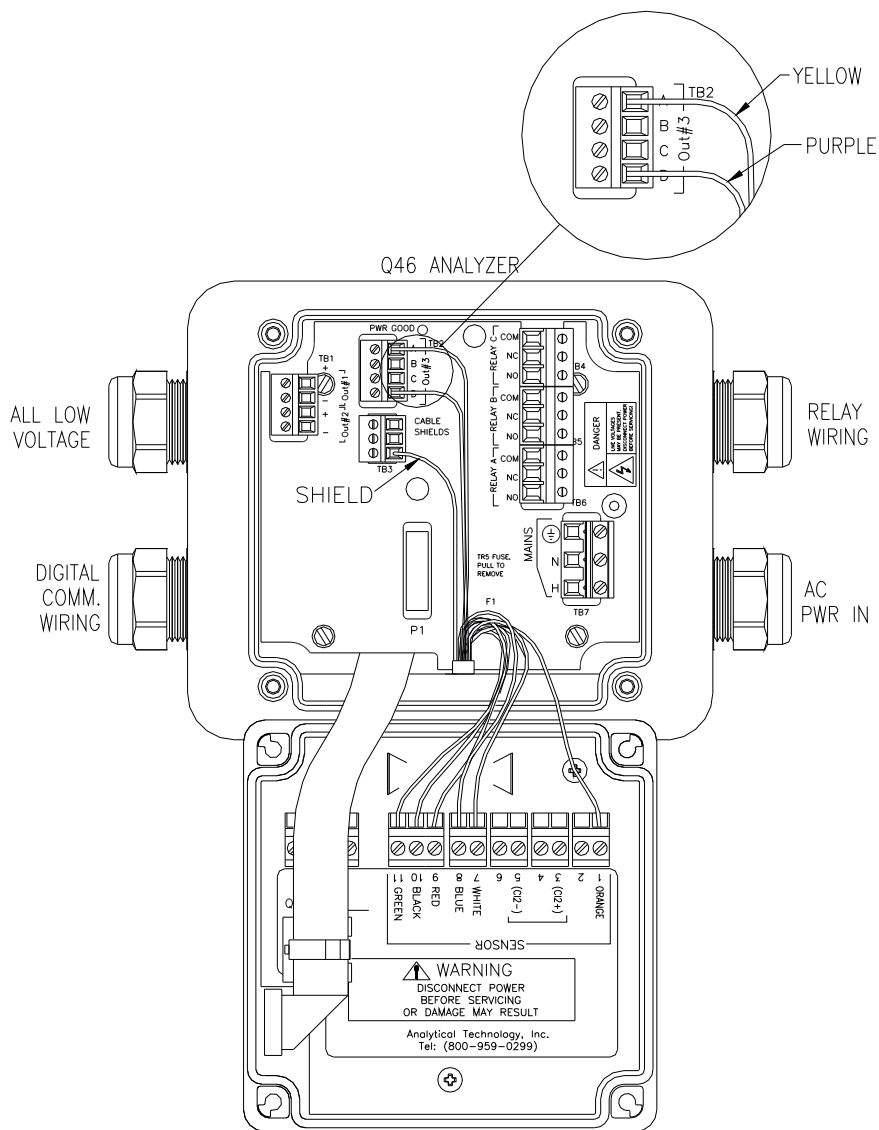

Figure 12 - Sensor and Control Connection

The standard 10 ft. cable supplied with the system is already terminated inside the Auto-Chem unit and is stripped and ready for wiring on the end to be connected to the Q46. Cord-grips used for sealing the cable should be snugly tightened after electrical connections have been made to prevent moisture incursion. When cutting multi conductor cable used for this system, be sure to strip back the cable jacket by 4 inches to ensure individual conductors can be routed properly inside the Q46F enclosure.

### 3.4 Relay Wiring

Three SPDT relays are provided on the power supply board. None of the relay contacts are powered. The user must supply the proper power to the contacts. For applications that require the same switched operating voltage as the Q46 (115 or 230 V), power may be jumpered from the power input terminals at **TB7**. Relay wiring is connected at **TB4, TB5, and TB6** as shown below. Note that the relay contact markings are shown in the NORMAL mode. Programming a relay for “Failsafe” operation reverses the NO and NC positions in this diagram (Figure 12).

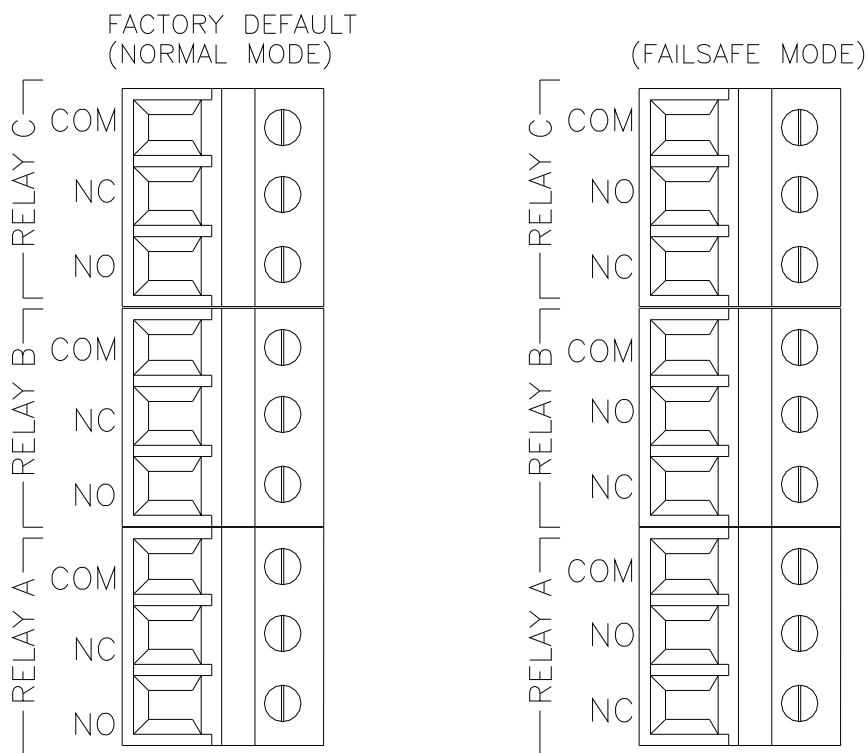

Figure 13 - Relay Contacts

### 3.5 Auto-Chem Power Panel

The chemistry module contains terminals and power supplies on a DIN rail located behind the front panel. Almost all connection to this assembly have been made at the factory. Your only connections at installation are the AC power connections to the terminal blocks on the right side.

Should you ever need to do service or testing on the power panel, it is often convenient to completely remove the front panel, allowing easy access to terminals. To remove the front panel, first disconnect the inlet and outlet luer fittings from the inlet overflow chamber. Disconnect reagent tubes from the reagent pump. Open the latch at the top of the panel and allow the panel to hinge forward. A retaining strap will stop the panel from moving too far.

The two pumps are plugged into the 24 VAC power supply on the right. The heater and RTD connections for the temperature control block are provided with molex connectors that can be unplugged to facilitate removal of the front panel. Pump motors can be disconnected at their molex plugs or the terminal blocks from the power supply can be unplugged.

Once everything is disconnected, open the Velcro on the retaining strap and slide the strap through the slots on the front panel. At this point, the entire front panel can be removed from the enclosure. Below is a photo of the interior showing power supplies and terminals.

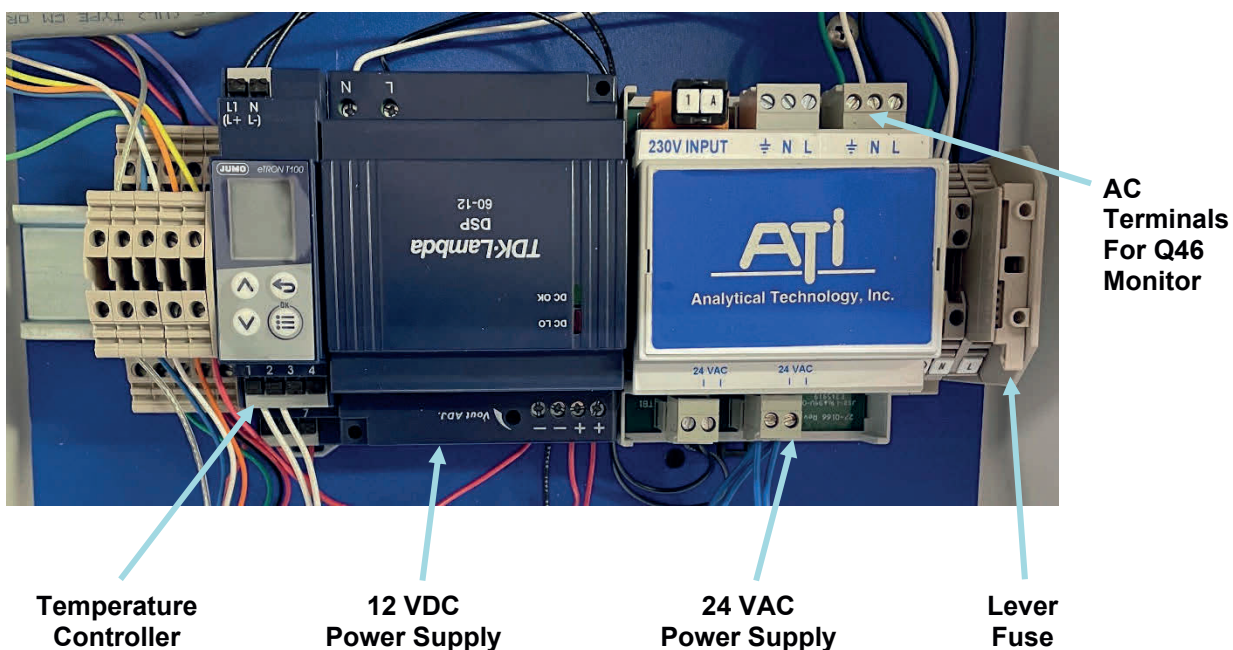

Figure 14 – Auto-Chem Connection Panel

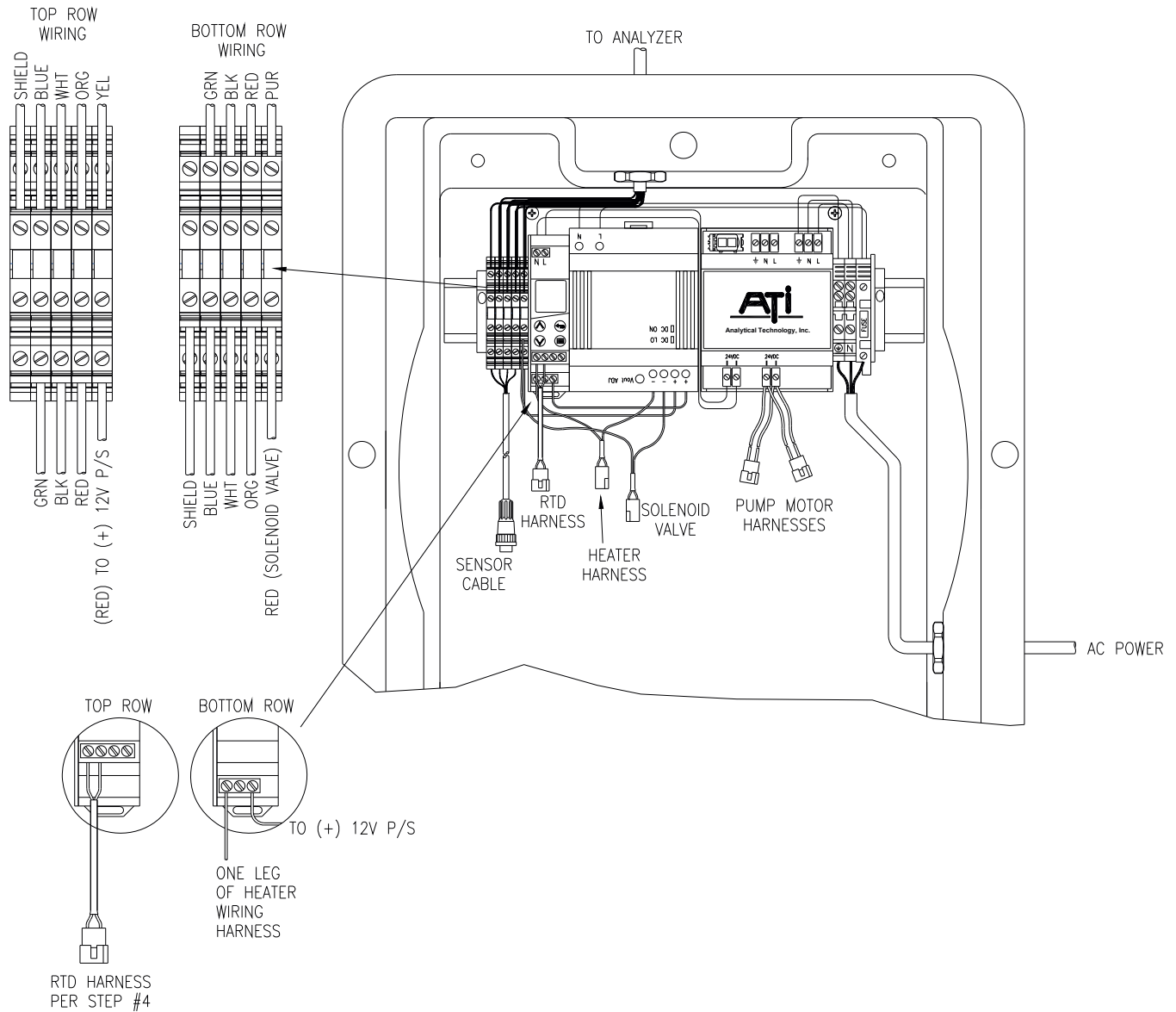

Figure 15 - Auto-Chem Internal Wiring

### 3.6 Auto-Chem to Q46 Power Interconnect

In some installations, it may be convenient to provide power to the Q46 monitor through terminals provided on the 24 VAC power supply. The advantage of this arrangement is that the lever fuse in the Auto-Chem module can be used to turn power on and off in both the chemistry unit and the monitor.

Refer to Figure below. On the top side of the 24 VAC power supply you will see a 3-point terminal block that is unused. It is just left of the AC power connections that are factory wired. Connection of a 3-conductor AC power cord from these terminals up to TB7 of the Q46N electronics will power the Q46N through the chemistry module.

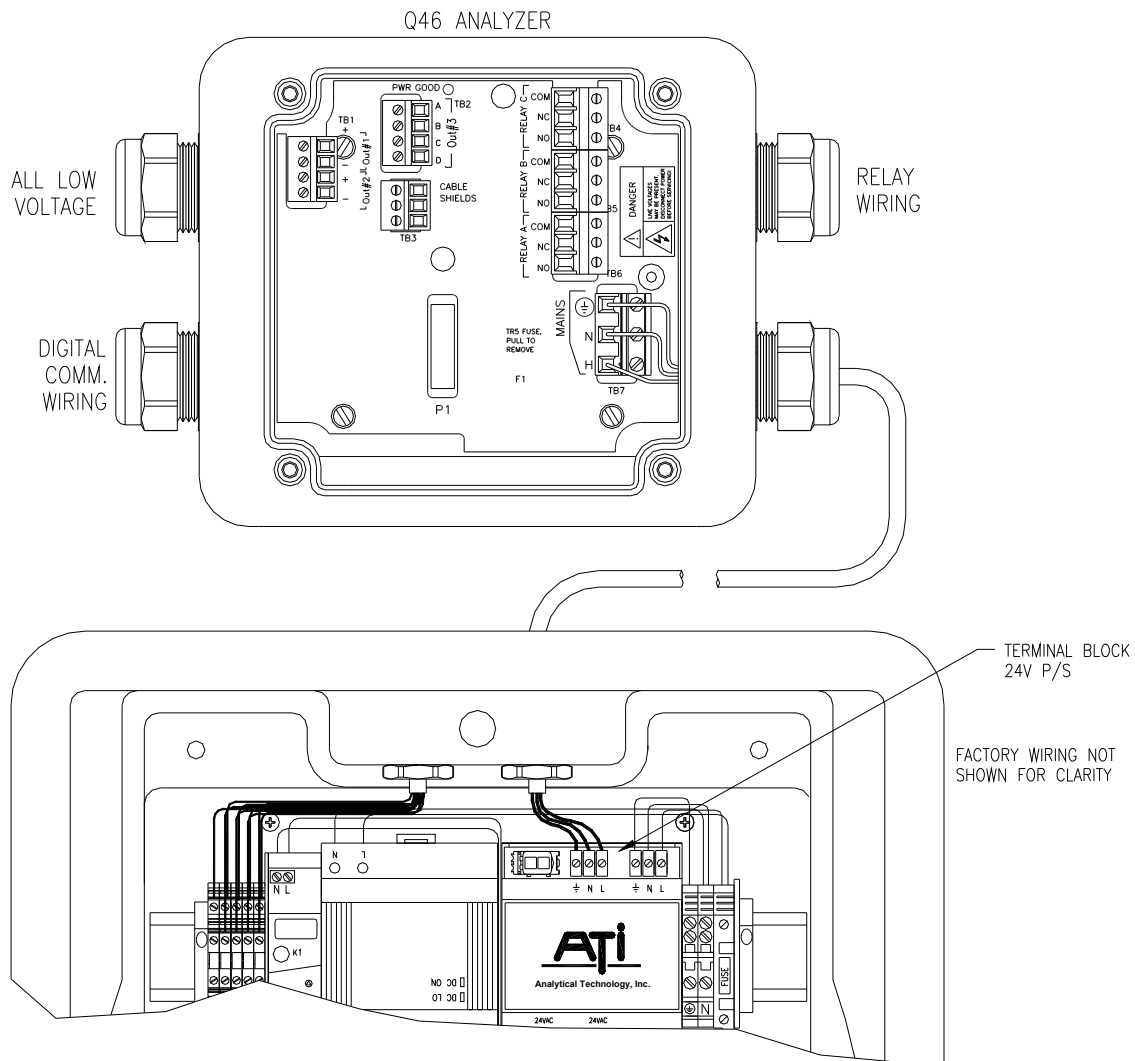

Figure 16 - Analyzer Connection from Autochem

# Part 4 – Auto-Chem Startup

## 4.1 General

The Auto-Chem chemistry module is the heart of the free ammonia system. In this module are the pumps, sample temperature control, flow cell, and a sensor required to make an accurate ammonia measurement.

In the chemistry system, raw sample flows into an overflow assembly attached to the bottom of the enclosure. Sample from this overflow is pumped into the enclosure where a reagent is injected into the sample to convert the ammonia into monochloramine. Excess chlorine is then removed by a second reagent prior to the measuring sensor. Sample temperature is controlled to a fixed value to provide maximum measurement stability.

The chemistry module is factory assembled, and only requires the reagent feed tubes to be attached to the reagent pump. The sensors must be “charged” before operation is possible.

## 4.2 Sensor Preparation

The sensor supplied with the Q46TN is shipped dry. It will not operate until prepared by adding electrolyte and a membrane. Preparation of the sensors for operation must be done carefully. **The procedure should be done by a qualified technician, and it should only be done when the system is ready for operation. Until then, it is best to leave the sensor in the condition in which it was received.** The sensor can be prepared up to 24 hours in advance if it is then stored with the sensor tips immersed in a container of tap water. Be careful not to immerse the connector on the back of the sensor.

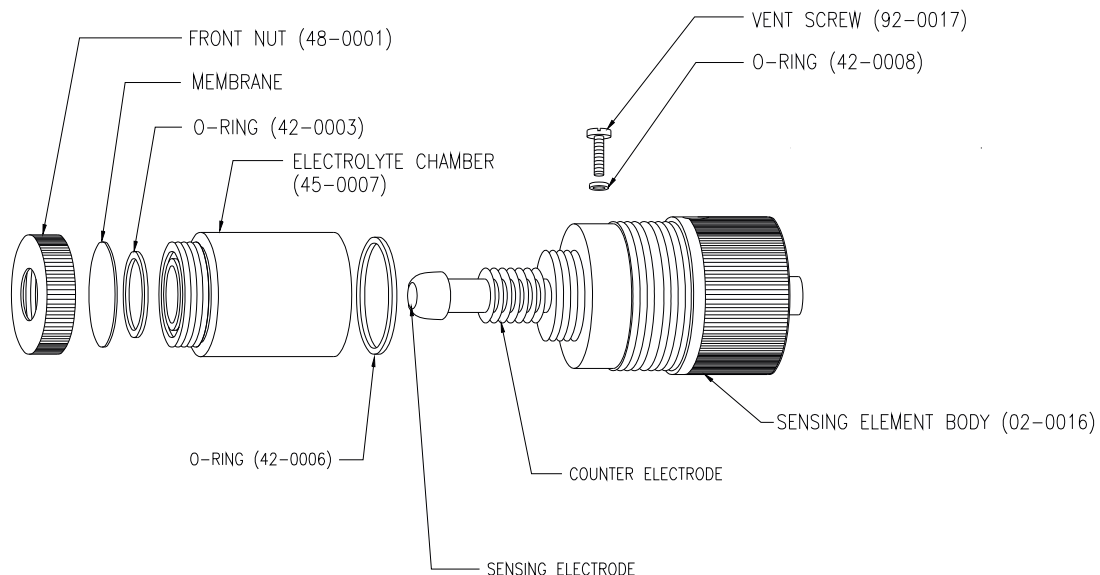

**Figure 17 - Sensor Exploded View**



Follow the procedure below to prepare the sensor for operation:

1. Unscrew the electrolyte chamber from the assembled sensor and also remove the vent screw from the side of the sensor body.
2. Remove the front nut from the bottom of the chamber and discard the protective membrane. O-rings are contained in grooves on both the bottom and top of the chamber. Be sure that these o-rings remain in place.
3. From the package of membranes supplied with the sensor, place a new membrane into the front nut. **The membrane is white in color and is separated from other membranes by a light blue paper spacer.**
4. Screw the front nut on to the chamber until you feel the o-ring compress. Hand tight compression is all that is needed. Do not use tools to tighten. The membrane should be flat across the bottom of the chamber without wrinkles.
5. Fill the chamber with electrolyte until the level reaches the bottom of the internal threads.
6. Slowly screw the chamber onto the sensor body. A small amount of electrolyte will run out of the hole from which the vent screw was removed. Place a paper towel around the sensor to absorb the electrolyte overflow. The electrolyte is harmless and will not irritate skin. Tighten the chamber until the o-ring at the top of the chamber is compressed. Once again, do not use tools to tighten.
7. Shake excess electrolyte from the fill hole on the side of the sensor and replace the vent screw.

The sensor is now ready for operation. The membrane should be stretched tightly across the tip of the sensor.

**CAUTION:** When handling the assembled sensor, do not set the sensor on its tip or damage to the membrane will result. Severe impacts on the tip of the sensor from dropping or other misuse may cause permanent damage to the sensor.

### 4.3 Reagent Preparation

The Q46TN requires three reagents for normal operation and three gallon containers are provided. The bottles are marked Reagent A, Reagent B, and Reagent C. These reagents must be mixed on site and are stable for only about 2 months after mixing. One gallon of each will operate the system for approximately 25 days.

#### Reagent A

This reagent is a mixture of bleach, distilled water and buffer (09-0074). You will need to purchase a bottle of Clorox bleach from a local market. The buffer is supplied by ATI in a container suitable for mixing one gallon. Note that the bleach referenced here is about 6% hypochlorite. You may use other strengths of sodium hypochlorite solution as long as the volume is adjusted to correct for the different strength. Contact ATI if you have any questions about this.

To the bottle marked Reagent A, add ½ gallon of distilled (or deionized) water and then add the container of the 09-0074 Reagent A Buffer. Swirl the container to mix the buffer occasionally over the course of 5 minutes to dissolve the buffer.

After the buffer has dissolved, add 600-650 cc of Clorox bleach (or any 5-6% sodium hypochlorite solution). Cap the bottle and invert a few times to mix. Fill the container to the neck with distilled water and mixture is now ready for use.

Place the reagent pickup assembly into the mouth of the bottle. **The pickup assembly should use the blue tubing provided.**

### **Regent B**

This reagent is a hydrogen peroxide solution. A 500 cc bottle of 27% peroxide is supplied separately to customers within the continental U.S. Customers outside the U.S. must source peroxide locally. Any peroxide solution in the 25-30% concentration range will be fine.

Take the bottle marked Reagent B and fill it halfway with distilled water. Then carefully add 150-160 cc of the peroxide concentrate into the bottle. Fill the bottle to the neck with distilled water. This reagent is ready immediately.

Place the reagent pickup assembly with red tubing into the mouth of the bottle.

**CAUTION:** Hydrogen peroxide solutions at 25-30% are hazardous. Avoid all contact with skin and eyes. Severe burns can result. Use protective gloves and eyewear when mixing Reagent B. Once diluted to one gallon, this solution is much less hazardous, having a concentration similar to that of peroxide sold in drug stores for disinfection of small cuts and scrapes.

**Make special note** of the need for protective gloves when handling new bottles of peroxide. These bottles are often shipped in sealed plastic bags, and peroxide residue may be present on the outside surface of the bottle. It is a good idea to simply rinse the outside of the unopened bottle with tap water prior to handling the bottle without protective gloves.

Please note also that skin contact with the concentrated peroxide solution should be rinsed immediately. Even after rinsing, you may find that the contacted skin has been bleached (will turn white). This is a temporary situation, and your skin will return to normal after a few hours. There is no permanent damage from this brief contact.

### **Regent C**

This reagent is a water solution containing 150 grams of a sample stabilizer which is meant to minimize possible calcium precipitation within the system. A container of 09-0075 stabilizer is supplied with the free ammonia system.

To prepare reagent C, fill the bottle marked Reagent C about ¾ full of distilled water and then pour in the contents of the 09-0075 container. Cap the bottle and invert a few times. The stabilizer takes a long time to completely dissolve and you will need to mix the solution periodically over the course of about 4 hours.

Once the stabilizer is dissolved, fill the Reagent C bottle to the neck with distilled water and insert the pickup assembly. Mixing Reagent C 24 hours in advance is recommended as it ensures complete dissolution of the chemical.

#### 4.4 Reagent Pump Priming

Reagents are pulled from the gallon containers by a peristaltic pump in the Auto-Chem. The pump rate for chemical feed is about 0.1 cc/min. It can take up to 20 minutes for buffer to reach the sample injection point when power is first applied.

Reagent tubing is color coded, blue for reagent A, red for reagent B, and clear for reagent C. Be sure that the proper connections have been made to the reagent pump and that the proper tubing color connects to the correct reagent bottle.

If desired, the reagent feed tube can be manually filled to reduce the waiting time. Two 5 cc syringes with plastic tips are supplied for this purpose. Use the two syringes to prime Reagent A and B tubes first and then use one of the syringes to prime Reagent C. To fill the A & B feed tubes, release the pressure on the reagent pump tube by loosening the clamp plate on the left side of the pump. Then disconnect the 1/16" I.D. tube from the injection tees, one just above the solenoid valve and one on the outlet tube from the sample pump. Insert the tip of the syringe into Reagent A tube and use the syringe to draw reagent from the bottle into the syringe. Leave that syringe attached to the tube and connect the second syringe to Reagent B tube and draw up that reagent to the syringe.

Leave both syringes connected and replace the pressure plate on the reagent pump. Once the pressure plate is properly seated, disconnect two syringes and connect the tubing to the injection tees. Discard any buffer in the syringes and rinse with tap water. After A & B are done, repeat the procedure for Reagent C, loosening the pressure plate on the right side of the pump and disconnecting the 1/16" I.D. tube from the injection point below the solenoid.

#### 4.5 Sensor Installation

The ammonia sensor is installed in the flowcell inside the chemistry module above the sample temperature control block. Please note that the luer check valve located on the outlet fitting from that block must be removed prior to inserting the sensor into the block. This is necessary to provide a vent for the block, which is normally sealed.

**Caution:**        **The ammonia sensor contains a vent, which is the small white dot you see on the electrolyte chamber. That white dot needs to be located at the top of the flowcell for proper sensor operation.**

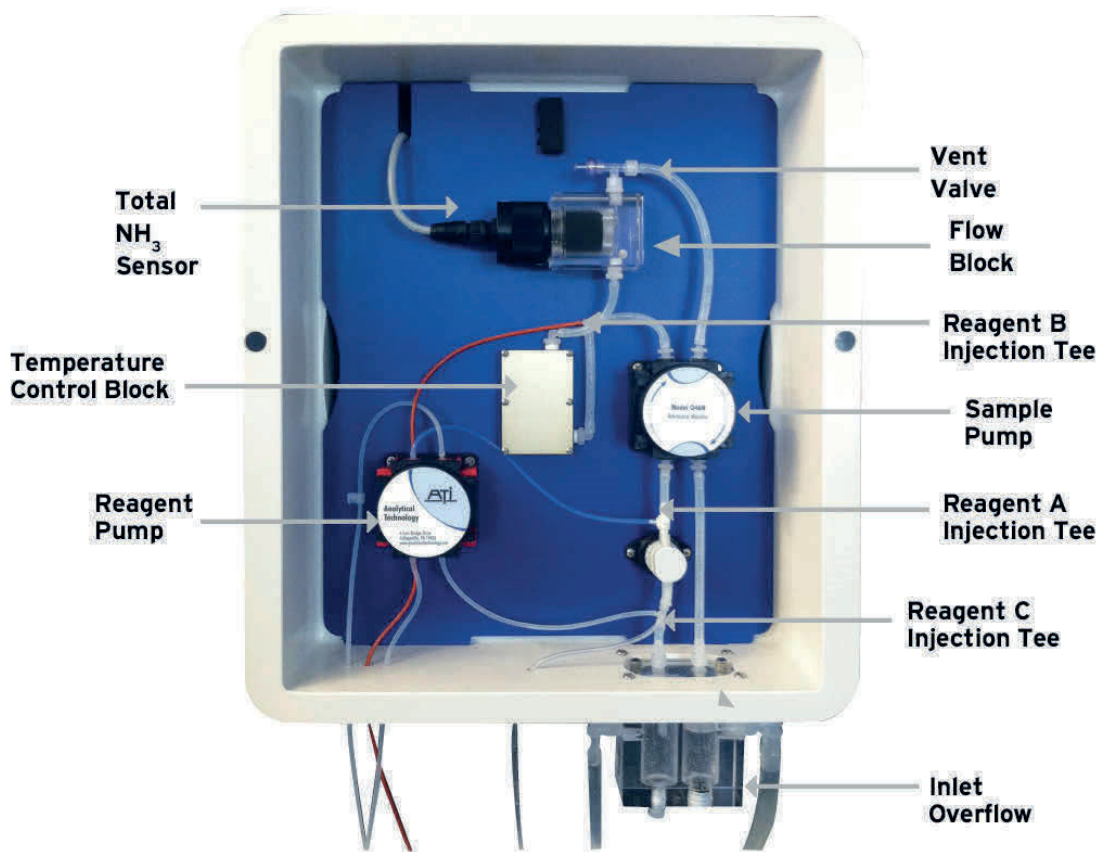

**Figure 18 – Auto-Chem Panel Components**

## 4.6 Operation

Before starting, be sure that the sensor has been prepared properly. As noted in the “Electrical Installation” section, the chemistry module contains a lever fuse holder that can be used to turn the chemistry system on and off. Once the steps outlined earlier in this section are complete and power has been connected to the proper terminals, simply close the lever fuse to activate the chemistry module.

Once power is applied, the two peristaltic pumps will start to turn. If the power to the Q46 comes on at the same time, you might hear the large solenoid valve under the sample pump cycle once. This is normal.

Assuming that sample is flowing to the overflow assembly, sample will be pulled out of the inlet chamber and will be pumped through the system. Unless reagent tubes were primed manually, let the system run for 30 minutes to allow reagents to reach the injection points and for sensors to stabilize. Do not be concerned with values shown on the monitor display during this period as they will not be valid until calibration has been done.

## 4.7 Temperature Adjustment

The Q46TN free ammonia monitor contains a temperature controller that adjusts the reacted sample to a fixed temperature. The controller is factory set to maintain the sample at 30° C. It is preferable to maintain the sample temperature at slightly above the highest expected sample inlet temperature. For most water applications, the factory setting will be sufficient. However, if your sample temperature normally exceeds 30° C, the temperature controller setpoint should be increased.

The temperature controller is located on the power panel as shown on page 22. Factory set value of 30° is displayed on the lower display areas on the controller. Adjustment of required can be performed by using the up or down arrows until the desired value is reached and then by pressing the confirm changes button .

## 4.8 Response Verification System

Q46TN Total Ammonia Monitors are sometimes used for monitoring sample streams that do not contain ammonia under normal conditions. Chilled water coming from ammonia chillers is an example. Normally, no ammonia is present but leaks in heat exchangers can release ammonia into the chilled water. Since the monitor is normally reading zero ammonia, users may want an automated method for testing the system periodically to verify that the system is still responding to ammonia.

The Q46TN provides a system that allows for automatic testing to ensure that response to ammonia is verified periodically. The system can be triggered either using an internal time or by connection of a contact closure to an input in the monitor. Note that it cannot do both, it must be one or the other.

To use this system, a 4<sup>th</sup> bottle must be added and the pickup tube from this bottle must be connected to a fitting just below the solenoid valve below the sample pump. A bottle marked “1 PPM” is supplied with the system. The 1 PPM solution can be mixed using the procedure outlined in the “Calibration” section of the manual.

The configuration section of the manual provides information on programming the “Timer Functions” that control the automated test. The typical test will use 1 PPM ammonia and will look for a stable response between 0.8 and 1.2 PPM. These limits are wide enough to allow small variation in mixing of the standard as well as small changes in the standard with time. These 1 PPM standards should be changed every 30 days, more frequently if you set tighter limits.

If you use the internal timer (T1 setting), set the frequency as desired. A frequency of once a day or once every 2 days is normally adequate. Each test will use about 150 ml. of the 1 PPM standard.

If you use the remote input to trigger the test, the Timer Function must be set to T2. A contact closure wired as shown in the following diagram will start the test. That contact closure can be activated remotely through a telemetry system is desired.

Note that the analog output designated lout #1 can be set to either track the ammonia value during the test or remain inhibited. Refer to the Configuration section for the setting of this option.

Figure 19 below shows the connection of a 1 PPM ammonia solution to the chemistry system. The tube from the bottle is fed through a hole in the bottom of the enclosure and connected to a 1/16" I.D. barb just below the solenoid valve.

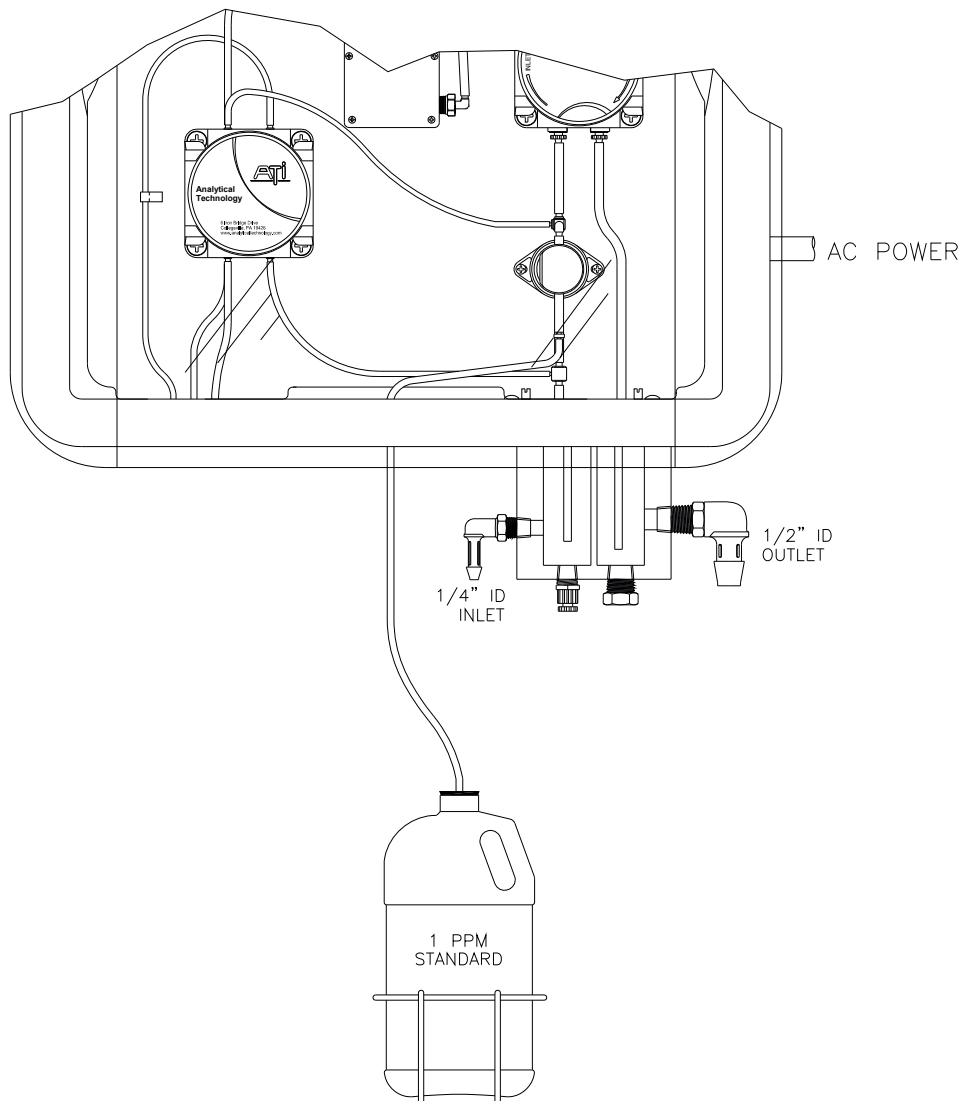
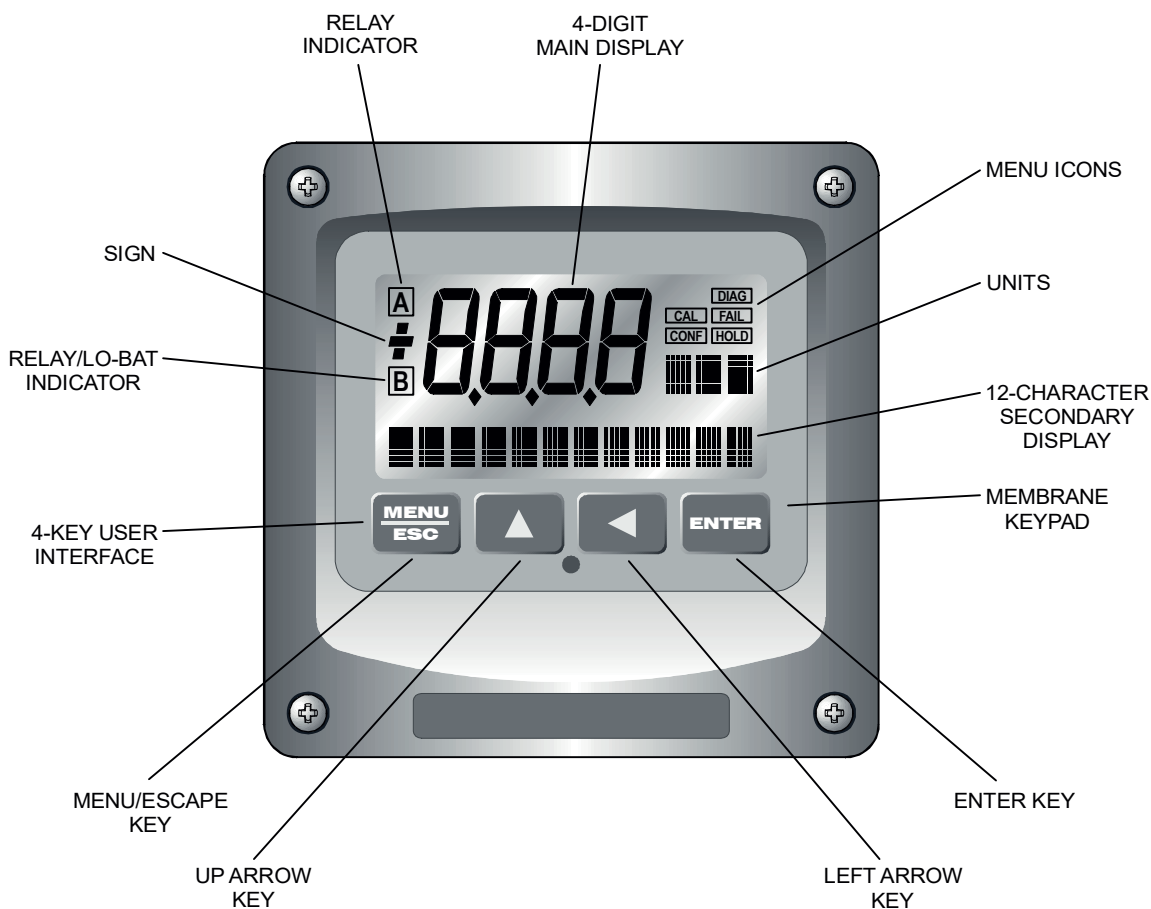

**Figure 19 – Response Verification System Diagram**

## Part 5 – Configuration

### 5.1 User Interface

The user interface for the Q46 Series instrument consists of a custom display and a membrane keypad. All functions are accessed from this user interface (no internal jumpers, pots, etc.).



**Figure 20 - User Interface**

## 5.11 Keys

All user configurations occur through the use of four membrane keys. These keys are used as follows:

<b>MENU/ESC</b>	To scroll through the menu section headers or to escape from anywhere in software. The escape sequence allows the user to back out of any changes in a logical manner. Using the escape key aborts all changes to the current screen and backs the user out one level in the software tree. The manual will refer to this key as either MENU or ESC, depending upon its particular function. In the battery-powered version of the Q46, this is also the ON button.
<b>UP (arrow)</b>	To scroll through individual list or display items and to change number values.
<b>LEFT (arrow)</b>	To move the cursor from right to left during changes to a number value.
<b>ENTER</b>	To select a menu section or list item for change and to store any change.

## 5.12 Display

The large custom display provides clear information for general measurement use and user configuration. There are three main areas of the display: the main parameter display, the secondary message line, and the icon area.

**Main Parameter** During normal operation, the main parameter display indicates the present process input with sign and units. This main display may be configured to display any of the main measurements that the system provides. During configuration, this area displays other useful set-up information to the user.



**Lower Line** During normal operation, the lower line of the display indicates user-selected secondary measurements that the system is making. This also includes calibration data from the last calibration sequence and the transmitter model number and software version. During configuration, the lower line displays menu items and set-up prompts to the user. Finally, the lower line will display error messages when necessary. For a description of all display messages, refer to Section 9.4.

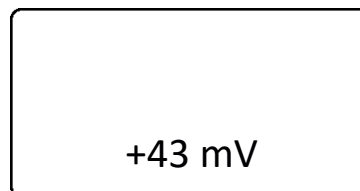



**Icon Area**

The icon area contains display icons that assist the user in set-up and indicate important states of system functions. The CAL, CONFIG, and DIAG icons are used to tell the user what branch of the software tree the user is in while scrolling through the menu items. This improves software map navigation dramatically. Upon entry into a menu, the title is displayed (such as CAL), and then the title disappears to make way for the actual menu item. However, the icon stays on.

**HOLD**

The HOLD icon indicates that the current output of the transmitter has been put into output hold. In this case, the output is locked to the last input value measured when the HOLD function was entered. HOLD values are retained even if the unit power is cycled.

**FAIL**

The FAIL icon indicates that the system diagnostic function has detected a problem that requires immediate attention. This icon is automatically cleared once the problem has been resolved.

**Relay Area A/B**

The relay area contains two icons that indicate the state of the system relays (if the relay card is installed). Relay C is normally configured for FAIL indication, so it is only displayed on the lower MEASURE display line.

**5.2 Software**

The software of the Q46F is organized in an easy to follow menu-based system. All user settings are organized under five menu sections: Measure, Calibration [CAL], Configuration [CONFIG], Control [CONTROL] and Diagnostics [DIAG].

**Note: The default Measure Menu is display-only and has no menu icon.**

## 5.21 Software Navigation

Within the CAL, CONFIG, CONTROL, and DIAG menu sections is a list of selectable items. Once a menu section (such as CONFIG) has been selected with the MENU key, the user can access the item list in this section by pressing either the ENTER key or the UP arrow key. The list items can then be scrolled through using the UP arrow key. Once the last item is reached, the list wraps around and the first list item is shown again. The items in the menu sections are organized such that more frequently used functions are first, while more permanent function settings are later in the list. See Figure 21 for a visual description of the software.

Each list item allows a change to a stored system variable. List items are designed in one of two forms: simple single variable, or multiple variable sequences. In the single variable format, the user can quickly modify one parameter - for example, changing the display range from 2.000 to 20.00. In the multiple variable sequence, variables are changed as the result of some process. For example, the calibration of ammonia generally requires more than one piece of information to be entered. The majority of the menu items in the software consist of the single variable format type.

Any data that may be changed will be flashing. This flashing indicates user entry mode and is initiated by pressing the ENTER key. The UP arrow key will increase a flashing digit from 0 to 9. The LEFT arrow key moves the flashing digit from right to left. Once the change has been completed, pressing ENTER again stores the variable and stops the flashing. Pressing ESC aborts the change and also exits user entry mode.

The starting (default) screen is always the Measure Menu. The UP arrow key is used to select the desired display. From anywhere in this section the user can press the MENU key to select one of the four Menu Sections.

The UP arrow icon next to all list items on the display is a reminder to scroll through the list using the UP arrow key.

To select a list item for modification, first select the proper menu with the MENU key. Scroll to the list item with the UP arrow key and then press the ENTER key. This tells the system that the user wishes to perform a change on that item. For single item type screens, once the user presses the ENTER key, part or all of the variable will begin to flash, indicating that the user may modify that variable using the arrow keys. However, if the instrument is locked, the transmitter will display the message **Locked!** and will not enter user entry mode. The instrument must be unlocked by entering the proper code value to allow authorized changes to user entered values. Once the variable has been reset, pressing the ENTER key again causes the change to be stored and the flashing to stop. The message **Accepted!** will be displayed if the change is within pre-defined variable limits. If the user decides not to modify the value after it has already been partially changed, pressing the ESC key aborts the modification and returns the entry to its original stored value.

In a menu item which is a multiple variable sequence type, once the ENTER key is pressed there may be several prompts and sequences that are run to complete the modification. The ESC key can always be used to abort the sequence without changing any stored variables.

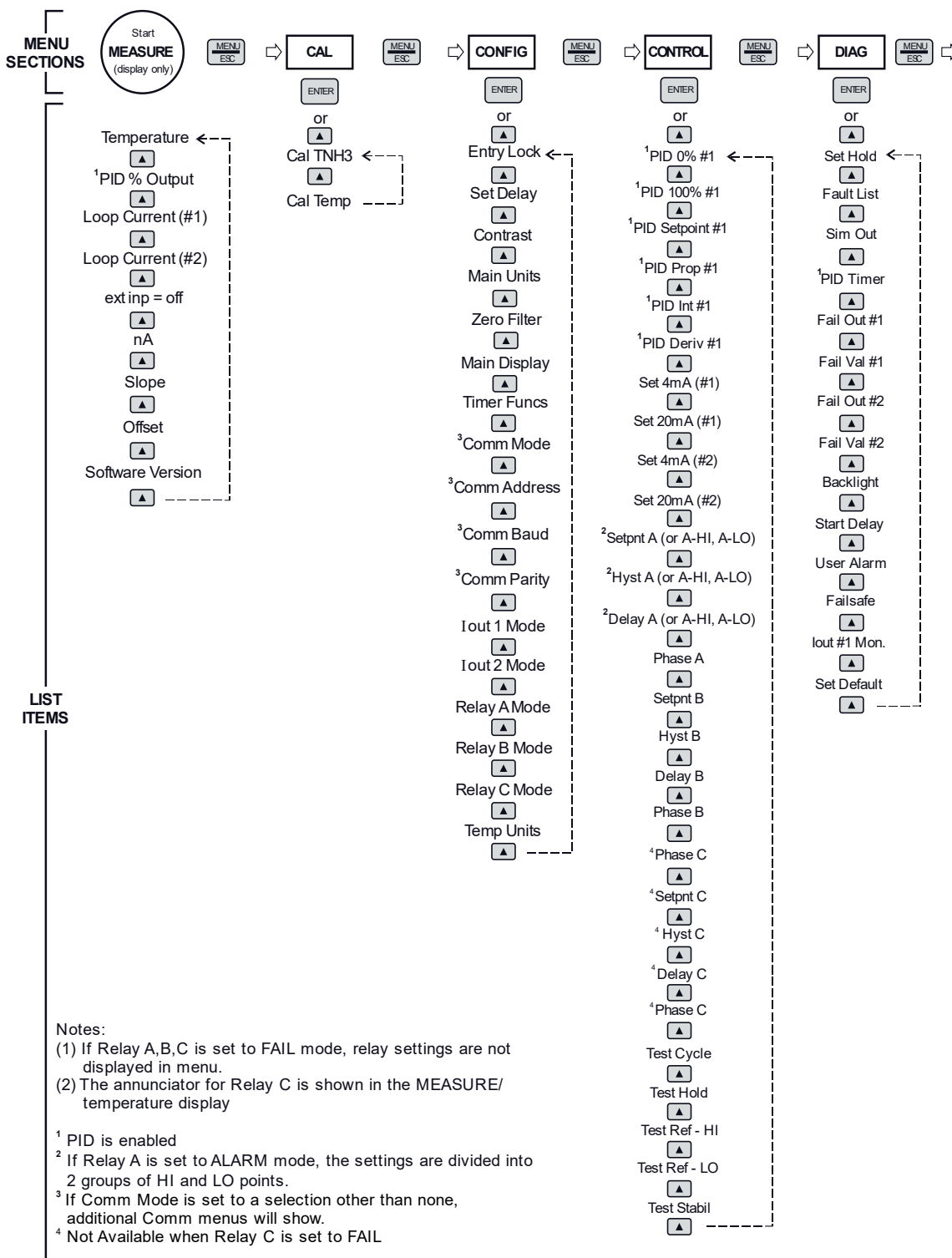

Figure 21 - Software Map

## 5.22 Measure Menu [MEASURE]

The default menu for the system is the display-only menu MEASURE. This menu is a display-only measurement menu, and has no changeable list items. When left alone, the instrument will automatically return to this menu after approximately 30 minutes. While in the default menu, the UP arrow allows the user to scroll through the secondary variables on the lower line of the display. A brief description of the fields in the basic transmitter version is as follows:

### TRANSMITTER MEAS SCREENS:

<b>TNH3 25.7C</b>	Temperature display. User selectable for °C or °F. A small “m” to the left of the temperature indicates the monitor has automatically jumped to a manual 25C setting due to a failure with the temperature signal input.
<b>100% 20.00 mA</b>	PID Status screen (if enabled.) Shows the present controller output level on left, and actual transmitter current on the right. The controller can be placed in manual while viewing this screen by pressing and holding the ENTER key for 5 seconds until a small flashing “m” appears on the screen. At that point the controller output can be adjusted up or down using the UP and LEFT arrow keys. To return to automatic operation, press and hold the ENTER key for 5 seconds and the “M” will disappear.
<b>4.00 mA</b>	Transmitter output current # 1
<b>20.00 mA</b>	Transmitter output current # 2
<b>Ext Inp OFF</b>	Indicates whether the monitor is receiving a digital input from an outside device. When OFF, input is open. When ON, input is closed.
<b>xx nA</b>	Raw sensor signal. Useful for diagnosing problems.
<b>Slope = 100%</b>	Sensor output response vs. ideal calibration. This value updates after each calibration. As the sensor ages, the slope reading will decay indicating sensor aging. Useful for identifying potential sensor problems.
<b>Offset = 0.0 na</b>	Indicates the last stored sensor zero value in nanoamps.
<b>Q46N0 vX.XX</b>	Transmitter software version number.
<b>T1-cyc XX.Xh</b>	Time until next automatic verification test. Only appears when Timer Function is activated in Config Menu.

**Note:** A display test (all segments ON) can be actuated by pressing and holding the ENTER key while viewing the model/version number on the lower line of the display.

**An automatic testing cycle can be activated manually by holding the ENTER key while viewing the T-cyc value.**

The MEASURE screens are intended to be used as a very quick means of looking up critical values during operation or troubleshooting.

### 5.23 Calibration Menu [CAL]

The calibration menu contains items for frequent calibration of user parameters. There are three items in this list: Cal Total Ammonia, Cal NH<sub>2</sub>Cl, and Cal Temp.

**Cal TNH3** This functions the user to adjust the transmitter span reading to match a reference solution, or to set the sensor zero point. See Part 6 - Calibration for more details.

**Cal Temp** The temperature calibration function allows the user to adjust the offset of the temperature response by a small factor of  $\pm 5$  °C. The temperature input is factory calibrated to very high accuracy. However, long cable lengths and junction boxes may degrade the accuracy of the temperature measurement in some extreme situations. Therefore, this feature is provided as an adjustment. See Part 6 - Calibration for more details.

### 5.24 Configuration Menu [CONFIG]

The Configuration Menu contains all of the general user settings:

**Entry Lock** This function allows the user to lock out unauthorized tampering with instrument settings. All settings may be viewed while the instrument is locked, but they cannot be modified. The Entry Lock feature is a toggle-type setting; that is, entering the correct code will lock the transmitter and entering the correct code again will unlock it. The code is preset at a fixed value. Press ENTER to initiate user entry mode and the first digit will flash. Use arrow keys to modify value. **See last page for the Q46N lock/unlock code.** Press ENTER to toggle lock setting once code is correct. Incorrect codes do not change state of lock condition.

**Set Delay** The delay function sets the amount of damping on the instrument. Both the display and the output value are affected by the degree of damping. Functions such as calibration are not affected by this parameter. The calibration routines contain their own filtering and stability monitoring functions to minimize the calibration timing. Press ENTER to initiate user entry mode, and the value will flash. Use the arrow keys to modify value; range is 0.1 to 9.9 minutes. Press ENTER to store the new value.

**Contrast** This function sets the contrast level for the display. The custom display is designed with a wide temperature range, Super-Twist Nematic (STN) fluid. The contrast is set to 8 and generally does not need adjustment.

**Main Units** This function allows the user to select either PPM or mg/l.

**Zero Filter** This function forces the reading to zero when reading is below the entered value. For example, if the entered value were 0.0020 the display at 0-0019 would indicate 0.000. This feature is useful in blanking out zero noise.

**Main Display** This function allows the user to change the measurement in the primary display area. The user may select between ppm, temperature, or %. Press ENTER to initiate user entry mode, and the entire value will flash. Use the UP arrow key to modify the desired display value. Press ENTER to store the new value.

<b>Timer Func</b>	Allows the user to activate the automatic response Verification system either using the internal timer (T1) or from an external digital input (T2).
<b>Com Mode</b>	Sets digital communication mode of analyzer. Optional digital communication card must be plugged into the power supply slot for this function to work. Press ENTER to initiate user entry mode, and the entire value will flash. Use the UP arrow key to modify the desired value; selections include 1-None, 2- P-DP for Profibus DP, 3 – Modbus, 4 – Ethernet IP. Press ENTER to store the new value.
<b>Com Address</b>	Sets bus address for digital communication mode of analyzer. Optional digital communication card must be plugged into the power supply slot for this function to work. Press ENTER to initiate user entry mode, and the entire value will flash. Use the UP arrow key to modify the desired value. Range is 1-125. Press ENTER to store the value.
<b>Com Baud</b>	Sets communications baud rate.
<b>Com Parity</b>	Sets parity for the digital communications.
<b>Iout#1 Mode</b>	This function sets analog output #1 to either track free ammonia (default) or enables the PID controller to operate on the ammonia input. Press ENTER to initiate user entry mode, and the entire value will flash. Use the UP arrow key to modify the desired value; selections include 1-ppm for ammonia tracking or 2-PID for ammonia PID control. Press ENTER to store the new value.
<b>Iout#2 Mode</b>	This function sets analog output #2 for either total ammonia, monochloramine as chlorine, monochloramine as nitrogen, or temperature. Press ENTER to initiate user entry mode, and the entire value will flash. Use the UP arrow key to modify the desired value. Press ENTER to store the new value.
<b>Rly A Mode</b>	Relay A can be used in three different ways: as a setpoint control, as a fail alarm, or as a HI-LO alarm band. The three settings for Rly A Mode are <b>CON</b> , <b>FAIL</b> and <b>AL</b> .  The <b>CON</b> setting enables normal control operation for Relay A, with settings for setpoint, hysteresis, delay and phasing appearing in the CONFIG menu automatically. See Figure 22 for further details.  The <b>FAIL</b> setting enables the fail alarm mode for Relay A. Relay A will then trip on any condition that causes the FAIL icon to be displayed on the LCD. Using this mode allows the User to send alarm indications to other remote devices.  The <b>AL</b> setting allows two setpoints to be selected for the same relay, producing a HI-LO alarm band. In this mode, Relay A will trip inside or outside of the band, depending upon the Phase selected. See Figure 23 for further details.

**Relay B Mode**  
**Relay C Mode** Relay B and C can be used in two ways: as a setpoint control, or as an alarm. The two settings for Relay B Mode are **CON** and **FAIL**.

The **CON** setting enables normal setpoint operation for Relay B/C. Relay B/C then operates identically to Relay A, with settings for setpoint, hysteresis, delay and phasing appearing in the CONFIG menu automatically. See Figure 19 for details.

The **FAIL** setting enables the fail alarm mode for Relay B/C. Relay B/C will then trip on any condition that causes the FAIL icon to be displayed on the LCD. Note that the Relay C indicator shows up only on the lower screen of the display next to the temperature reading. This is because the default setting for relay C is the **FAIL** setting. Using this mode allows the User to send alarm indications to other remote devices.

**Temp Units** This function allows the user to select a temperature display in either °C or °F.

## 5.25 Control Menu [CONTROL]

The Control Menu contains all of the output control user settings:

**Set 4 mA**  
**Set 20 mA**  
[Iout1=PPM] These functions set the main 4 and 20 mA current loop output points for the transmitter. The units displayed depend on the selection made in the CONFIG menu for Iout #1 Mode.

The value stored for the 4 mA point may be higher or lower than the value stored for the 20 mA point. The entry values are limited to values within the range specified in “Set Range”, and the 4 mA and the 20 mA point must be separated by at least 1% of this range. Use the LEFT arrow key to select the first digit to be modified. Then use the UP and LEFT arrow keys to select the desired numerical value. Press ENTER to store the new value.

**Set PID 0%**  
**Set PID 100%**  
[Iout1=PID] If the PID is enabled, this function sets the minimum and maximum controller end points. Unlike the standard 4-20 mA output, the controller does not “scale” output values across the endpoints. Rather, the endpoints determine where the controller would normally force minimum or maximum output in an attempt to recover the setpoint (even though the controller can achieve 0% or 100% anywhere within the range.)

If the 0% point is lower than the 100% point, then the controller action will be “reverse” acting. That is, the output of the controller will increase if the measured value is less than the setpoint, and the output will decrease if the measured value is larger than the setpoint. Flipping the stored values in these points will reverse the action of the controller to “direct” mode.

The entry value is limited to a value within the range specified in “Set Range”, and the 0% and the 100% point must be separated by at least 1% of this range. Use the LEFT arrow key to select the first digit to be modified. Then use the UP and LEFT arrow keys to select the desired numerical value. Press ENTER to store the new value.

<b>PID Setpnt</b> [Iout1=PID]	The measured value which the controller is attempting to maintain by adjusting output value. It is the nature of the PID controller that it never actually gets to the exact value and stops. The controller is continually making smaller and smaller adjustments as the measured value gets near the setpoint.
<b>PID Prop</b> [Iout1=PID]	Proportional gain factor. The proportional gain value is a multiplier on the controller error (difference between measured value and setpoint value.) Increasing this value will make the controller more responsive.
<b>PID Int</b> [Iout1=PID]	Integral is the number of “repeats-per-minute” of the action of the controller. It is the number of times per minute that the controller acts on the input error. At a setting of 2.0 rpm, there are two repeats every minute. If the integral is set to zero, a fixed offset value is added to the controller (manual reset.) Increasing this value will make the controller more responsive.
<b>PID Deriv</b> [Iout1=PID]	Derivative is a second order implementation of Integral, used to suppress “second-order” effects from process variables. These variables may include items like pumps or mixers that may have minor impacts on the measured value. The derivative factor is rarely used in water treatment process, and therefore, it is best in most cases to leave it at the default value. Increasing this value will make the controller more responsive.
<b>Set 4 mA #2</b> <b>Set 20 mA #2</b> [Temp / PPM]	<p>These functions set the second 4 mA and 20 mA current loop output points for the transmitter. The default setting for this output is temperature, but it may be set for PPM if preferred. The values stored for the 4 mA point may be higher or lower than the value stored for the 20 mA point.</p> <p>The entry value is limited to a value between 0 and 55°C if it is set for temperature. The 4 mA and the 20 mA point must be at least 20 units away from each other. Press ENTER to initiate user entry mode, and the value will flash. Use arrow keys to modify value. Press ENTER to store the new value.</p> <p>NOTE: If the temperature units are changed between °C and °F (see Temp Units in CONFIG section), the default setting for this output will change between 100°C and 212°F accordingly</p>
<b>A Setpoint</b>	This function establishes the trip point for relay A. The entry value is limited to a value within the range specified in “Set Range”. Use the LEFT arrow key to select the first digit to be modified. Then use the UP and LEFT arrow keys to select the desired numerical value. Press ENTER to store the new value.
<b>A Hysteresis</b>	This function establishes the hysteresis, or “deadband”, for Relay A. Hysteresis is most often used to control relay chattering; however, it may also be used in control schemes to separate the ON/OFF trip points of the relay. Press ENTER to initiate user entry mode, and the value will flash. Use the arrow keys to modify value. Press ENTER to store the new value.



**A Delay**

This function places an additional amount of time delay on the trip point for relay A. This delay is in addition to the main delay setting for the controller. The entry value is limited to a value between 0 and 999 seconds. Press ENTER to initiate user entry mode, and the value will flash. Use arrow keys to modify value; range is 0 to 999 seconds. Press ENTER to store the new value.

**A Phasing**

This function establishes the direction of the relay trip. When phase is HI, the relay operates in a direct mode. Therefore, the relay energizes and the LCD indicator illuminates when the value **exceeds** the setpoint. When the phase is LO, the relay energizes and the LCD indicator illuminates when the ammonia level drops **below** the setpoint. The failsafe setting does have an impact on this logic. The description here assumes the failsafe setting is OFF. Press ENTER to initiate user entry mode, and the entire value will flash. Use the UP arrow key to modify the desired value; selections include **HI** for direct operation or **LO** for reverse operation. Press ENTER to store the new value.

Figure 22 below for a visual description of a typical control relay application.

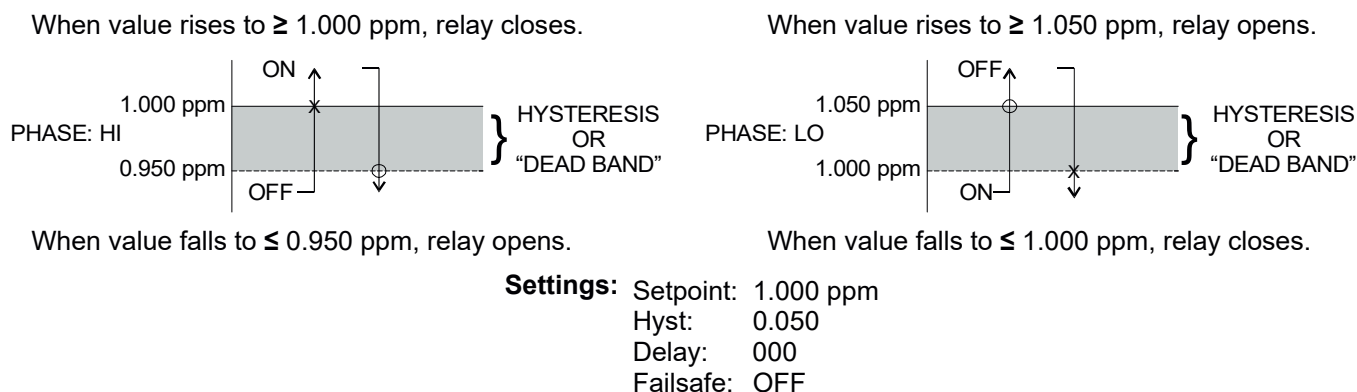

**Figure 22 - Control Relay Example**

- Setpnt A-HI
- Hyst A-HI
- Delay A-HI
- Setpnt A-LO
- Hyst A-LO
- Delav A-LO

If Relay A Mode is set to Alarm Mode, **AL**, then the following settings will appear in the Config Menu list automatically. In this mode, two setpoints can be selected on the same relay, to create an alarm band. Phase HI selection causes the relay to energize outside of the band, and Phase LO causes the relay to energize inside of the band. This feature enables one relay to be used as a control relay while the other is used as a HI-LO Alarm relay at the same time. Setpoint A-LO must be set lower than Setpoint A-HI. When AL mode is first selected, Setpoint A-LO is defaulted to 0.

Figure 23 is a visual description of a typical alarm relay application.

When value rises to  $\geq 1.000$  ppm, relay closes, until value falls back to  $\leq 0.950$  ppm.

When value falls to  $\leq 1.000$  ppm, relay closes, until rises back to  $\geq 1.050$  ppm.

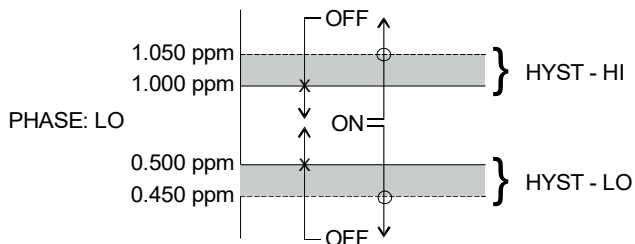
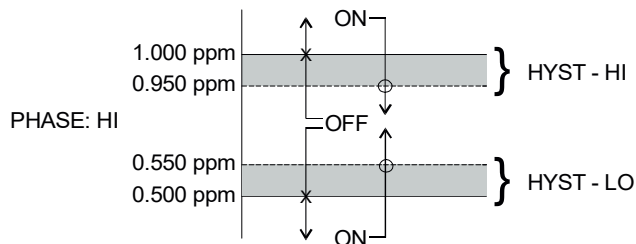

When value falls to  $\leq 0.500$  ppm, relay closes, until rises back to  $\geq 0.550$  ppm.

When value rises to  $\geq 0.500$  ppm, relay closes, until value falls back to  $\leq 0.450$  ppm.

**Settings:** Setpoint A-HI: 1.000 ppm  
 Hyst A-HI: 0.050  
 Delay A-HI: 000

Setpoint A-LO: .500 ppm  
 Hyst A-LO: .0.050  
 Delay A-LO: 000

Figure 23 - Alarm Relay Example

**B Setpoint**  
**B Hysteresis**  
**B Delay**  
**B Phasing**

If Relay B Mode is set to CON (see Relay B Mode), then Relay B will function identically to Relay A. Relay B settings appear in the CONFIG menu list automatically

**C Setpoint**  
**C Hysteresis**  
**C Delay**  
**C Phasing**

If Relay C Mode is set to CON (see Relay C Mode), then Relay C will function identically to Relay A. Relay C settings appear in the CONFIG menu list automatically.

**Test Cycle**

This function defines the time period between automatic test cycles if the Timer Function T1 is activated in the Config Menu. Typical cycles are every 24, 48, or 168 hours. Press ENTER to initiate user entry mode, and the value will flash. Use arrow keys to modify value; range is 0 to 999 hours. Press ENTER to store the new value.

**Test Hold**

Defines the number of minutes that the analog and relay outputs are held at the end of the test cycle. The default is 4 minutes and can be increased if necessary. Decreasing the value can end the hold cycle before the ammonia value has returned to zero, possibly triggering alarms in receiving instruments.

**Test Ref-Hi**

Automatic system verification is normally done with a 1 PPM ammonia standard. This setting defines a high limit for this test. The default is 1.2 PPM. If the measured value exceeds 1.2 PPM during the test, a failure alarm will be generated at the end of the test. The value may be increased or decreased as desired but should not be set below 1.1 PPM.

- Test Ref-Lo** This setting defines a low limit for the verification test. The default is 0.8 PPM. If the measured value does not go above 0.8 PPM during the test, a failure alarm will be generated at the end of the test. The value may be increased or decreased as desired but should not be set above 0.9 PPM.
- Test Stability** At the end of the test cycle, the monitor will evaluate the sensor signal for stability. If the sensor is unstable for more than the stability time programmed in this routine, a test failure will occur, and a fail alarm generated. The default is 2 minutes.

## 5.26 Diagnostics Menu [DIAG]

The diagnostics menu contains all of the user settings that are specific to the system diagnostic functions, as well as functions that aid in troubleshooting application problems.

- Set Hold** The Set Hold function locks the current loop output values on the present process value and halts operation of the PID controller. This function can be used prior to calibration, or when removing the sensor from the process, to hold the output in a known state. Once HOLD is released, the outputs return to their normal state of following the process input. The transfer out of HOLD is bumpless on the both analog outputs - that is, the transfer occurs in a smooth manner rather than as an abrupt change. An icon on the display indicates the HOLD state, and the HOLD state is retained even if power is cycled. Press ENTER to initiate user entry mode, and entire value will flash. Use the UP arrow key to modify the desired value, selections are **ON** for engaging the HOLD function, and **OFF** to disengage the function. Press ENTER to store the new value.

The Set Hold function can also hold at an output value specified by the user. To customize the hold value, first turn the HOLD function on. Press the ESC key to go to the DIAG Menu and scroll to Sim Output using the UP arrow key. Press ENTER. Follow the instructions under Sim Output (see following page).

- Fault List** The Fault List screen is a read-only screen that allows the user to display the cause of the highest priority failure. The screen indicates the number of faults present in the system and a message detailing the highest priority fault present. Note that some faults can result in multiple displayed failures due to the high number of internal tests occurring. As faults are corrected, they are immediately cleared.

Faults are not stored; therefore, they are immediately removed if power is cycled. If the problem causing the faults still exists, however, faults will be displayed again after power is re-applied and a period of time elapses during which the diagnostic system re-detects them. The exception to this rule is the calibration failure.

When a calibration fails, no corrupt data is stored. Therefore, the system continues to function normally on the data that was present before the calibration was attempted.

After 30 minutes or if power to the transmitter is cycled, the failure for calibration will be cleared until calibration is attempted again. If the problem still exists, the calibration failure will re-occur. Press ENTER to initiate view of the highest priority failure. The display will automatically return to normal after a few seconds.

**Sim Out**

The Sim Out function allows the user to simulate the ammonia concentration in the user selected display range. The user enters a ppm value directly onto the screen, and the output responds as if it were actually receiving the signal from the sensor. This allows the user to check the function of attached monitoring equipment during set-up or troubleshooting. Escaping this screen returns the unit to normal operation. Press ENTER to initiate the user entry mode, and the right-most digit of the value will flash. Use arrow keys to modify desired value.

**PID Timer**

This function sets a timer to monitor the amount of time the PID controller remains at 0% or 100%. This function only appears if the PID controller is enabled. If the timer is set to 0000, the feature is effectively disabled. If the timer value is set to any number other zero, a FAIL condition will occur if the PID controller remains at 0% or 100% for the timer value. If one of the relays is set to FAIL mode, this failure condition can be signaled by a changing relay contact.

Press ENTER to initiate user entry mode, and the entire value will flash. Use the UP arrow key to modify desired value; range of value is 0-9999 seconds. Press ENTER to store the new value.

**Fail Out #1**

This function enables the user to define a specified value that the main current output will go to under fault conditions. When the Relay Option Board is installed, the display will read **Fail Out #1**. When enabled to **ON**, the output may be forced to the current value set in **Fail Val** (next item.) With the Fail Out setting of ON, and a Fail Val setting of 6.5 mA, any alarm condition will cause the current loop output to drop outside the normal operating range to exactly 6.5 mA, indicating a system failure that requires attention.

Press ENTER to initiate user entry mode, and the entire value will flash. Use the UP arrow key to modify desired value; selections are **ON**, **OFF**. Press ENTER to store the new value.

**Fail Val #1**

Sets the output failure value for lout#1. When **Fail Out** above is set to **ON**, this function sets value of the current loop under a FAIL condition. When the Relay Option Board is installed, the display will read **Fail Out #1**. The output may be forced to any current value between 4-20 mA.

Press ENTER to initiate user entry mode, and the entire value will flash. Use the UP arrow key to modify desired value; selections are between **4mA**, and **20mA**. Press ENTER to store the new value.

<b>Fail Out #2</b>	This function sets the fail-mode of current loop output #2 under a FAIL condition. The settings and operation are identical to Fail Out for output #1.
<b>Fail Val #2</b>	This function sets the value of current loop output #2 under a FAIL condition. The settings and operation are identical to Fail Out for output #1.
<b>Backlight</b>	This function has three options. <b>ON</b> – On all the time, <b>OFF</b> – Off all the time, <b>AL</b> – Alarm (Default). This function flashes the backlight on and off whenever the Fail icon is displayed.
<b>Start Delay</b>	This function is designed to minimize control or alarm issues arising from temporary power loss. When power goes down, the monitor records the analog output values and the status of relays and PID functions. When power is restored, the analog values and relays will be held at the pre-power loss values for a defined period of time. This “start delay” may be programmed for periods from 0-9.9 minutes. This function is set to 0.0 minutes by default and must be activated by the user if desired by setting a positive time value
<b>User Alarm</b>	This function allows the user to enable a user alarm input. This function is intended to allow provision for a low reagent alarm for the system.
<b>Iout #1 Mon</b>	During an automatic verification test, the 4-20 mA output designated I out #1 may be either inhibited or not at the discretion of the user. With this function set to ON, the 4-20 mA output will be active during the test, allowing the results of the test to be recorded either locally or remotely. With this function OFF, the 4-20 mA output will remain at the output value at the start of the test.
<b>*Failsafe</b>	<p>This function allows the user to set the optional system relays to a failsafe condition. In a failsafe condition, the relay logic is reversed so that the relay is electrically energized in a normal operating state. By doing this, the relay will not only change state when, for example, a ammonia limit is exceeded, but also when power is lost to the controller.</p> <p>When failsafe is selected to be ON, the normally-open contacts of the relay will be closed during normal operation. In an attempt to make this configuration less confusing, the LCD icon logic is reversed with this setting, and the icon is OFF under this normal condition. Therefore, when the trip condition occurs, the closed N.O. contacts will be opened (relay de-energized), and the LCD icon will illuminate. In addition, a power fail would also cause the same contacts to open.</p>
<b>Set Default</b>	The Set Default function allows the user to return the instrument back to factory default data for all user settings. It is intended to be used as a last resort troubleshooting procedure. All user settings are returned to the original factory values. Hidden factory calibration data remains unchanged. Press ENTER to initiate user entry mode and the value <b>NO</b> will flash. Use the UP arrow key to modify value to <b>YES</b> and press ENTER to reload defaults.

# Part 6 – Calibration

---

## 6.1 Calibration

Calibration of the ammonia system is relatively easy because ammonia standards are easy to mix and relatively stable. System calibration can be done by first feeding distilled or spring water through the system to zero the sensor and then feeding a 1 PPM ammonia standard to calibrate.

The 1 PPM ammonia standard can be mixed using the 100 PPM standard supplied with the unit. A dilution kit consisting of a 10 ml. graduated cylinder and a 1000 ml. graduated cylinder are supplied for convenience.

Please note that the 100 PPM ammonia standard should be stable for 6 months or more if stored in a cool location. The ammonia standards are mixed using reagent grade ammonium chloride and can be mixed by your own laboratory if equipped with a good analytical balance. The standard is 100 PPM ammonia-nitrogen and consists of 0.382 grams of  $\text{NH}_4\text{Cl}$  in 1 litre of distilled water.

To facilitate calibration, a sample pickup extension tube is supplied with the system. This is nothing more than a 3 ft. length of tubing with a connector that mates with the connector on top of the inlet assembly. To use, disconnect the sample pickup tube from the top of the inlet assembly and connect the extension tube. The other end can then be placed in either distilled water for zero or in 1 PPM ammonia standard for calibration.

### 6.11 Total Ammonia Zero

Zeroing the total ammonia system can be done by feeding distilled or spring water into the system. Let the system run on zero ammonia water for 15 minutes and then use the procedure below to set the zero.

1. Scroll to the CAL menu section using the MENU key and press ENTER or the UP arrow key. **Cal TNH3** will then be displayed. Press Enter.
2. The screen will display a flashing **1-Ref** for span calibration or a **2-Zer** for zero calibration. Using the  $\uparrow$  key, set for a **2-Zer** and press ENTER.
3. The display will flash **Wait** and the system will begin analyzing the sensor signal for stability. The stability testing will take a few seconds. Do not press any keys during this time.
4. If accepted, the screen will display the message **PASS** with the new sensor zero offset value and then return to the main measurement display. If the zero fails, a message indicating the cause of the failure will be displayed and the FAIL icon will be turned on. The range of acceptable values for sensor zero are -25 to +25 nA. It may be necessary to rebuild the sensor as described in section 5.4, Sensor Assembly. Should the zero offset remain out of range and result in calibration failures, review the Service Section of this manual, then contact the ATI service department for further assistance

## 6.12 Total Ammonia Span

Total ammonia is calibrated by feeding an ammonia standard into the monitor. A 1 PPM standard is recommended. Ammonia standards are relatively easy to prepare using a 100 PPM standard supplied with the unit and the two graduated cylinders supplied for making a 100:1 dilution.

To mix your 1 PPM standard, pour 100 PPM ammonia standard into the 10 ml. cylinder to the 10 ml. mark. Pour this 10 ml. volume into the 1000 ml. cylinder and fill to the 1000 ml mark with spring water. If desired, transfer this 1 PPM solution into another container and mark as 1 PPM NH<sub>3</sub>-N or simply feed the standard directly out of the graduated cylinder using the pickup extension tube.

To connect an extension tube disconnect the sample inlet tube from the fitting on the inlet cover. The connection is a Luer fitting that disconnects by rotating counterclockwise. The extension tube has a fitting that mates with the sample pickup. Simply connect the two and put the other end of the extension tube into the container of 1 PPM NH<sub>3</sub> standard. Allow the unit to run on this standard for about 10 minutes. After 10 minutes of operation, the reading should be stable, and you are ready to adjust the monitor as follows:

1. Go to the CAL menu section using the MENU key and press ENTER or the UP arrow key. **Cal TNH3** will then be displayed.
2. Press the ENTER key. The screen will display a flashing **1-Ref** for span calibration or a **2-Zer** for zero calibration. Using the UP arrow key, set for a **1-Ref** span calibration and press ENTER.
3. The system now begins acquiring data for the calibration value. As data is gathered, the units for ppm and temperature may flash. Flashing units indicate that this parameter is unstable. The calibration data point acquisition will stop only when the data remains stable for a pre-determined amount of time. This can be overridden by pressing ENTER. If the data remains unstable for 10 minutes, the calibration will fail and the message **CalUnstable** will be displayed.
4. Once stability is verified, the screen will display the last measured ppm value and a message will be displayed prompting the user for the standard value. The user must then modify the screen value with the arrow keys to a value of 1.00 PPM and then press ENTER. The system then performs the proper checks.
5. If accepted, the screen will display the message **PASS** with the new sensor slope reading, then it will return to the main measurement display. If the calibration fails, a message indicating the cause of the failure will be displayed and the FAIL icon will be turned on. The range of acceptable values for sensor slope is 20% to 500%. It may be necessary to rebuild the sensor as described in section 5.4, Sensor Assembly. Should the slope value remain out of range and result in calibration failures, review the Service Section of this manual, then contact the ATI service department for further assistance.

## 6.2 Temperature Calibration

The temperature calibration sequence is essentially a 1-point offset calibration that allows adjustments of approximately  $\pm 5$  °C.

The temperature element is measuring the temperature of the sample inside the air stripping chamber. This temperature may, or may not, be close to the temperature of the water in the inlet overflow. Heat generated inside the chemistry module can sometimes cause the displayed temperature to be above the actual sample temperature. While temperature calibration is possible, it is not recommended. If you wish to calibrate the temperature system, proceed as follows:

1. Scroll to the CAL menu section using the MENU key and press ENTER or the UP arrow key.
2. Press the UP arrow key until **Cal Temp** is displayed.
3. Press the ENTER key. The message **Place sensor in solution then press ENTER** will be displayed. *Press ENTER to begin the calibration sequence.*
4. The calibration data gathering process will begin. The message **Wait** will flash as data is accumulated and analyzed. The °C or °F symbol may flash periodically if the reading is too unstable.
5. The message **Adjust value - press ENTER** will be displayed, and the right-most digit will begin to flash, indicating that the value can be modified. Using the UP and LEFT arrow keys, modify the value to your measured value. Adjustments up to  $\pm 5$  °C from the factory calibrated temperature are allowed. Press ENTER.

Once completed, the display will indicate **PASS** or **FAIL**. If the unit fails, the temperature adjustment may be out of range, the sensor may not have achieved complete temperature equilibrium, or there may be a problem with the temperature element. In the event of calibration failure, it is recommended to attempt the calibration again immediately.



# Part 7 – PID Controller Details

---

## 7.1 PID Description

PID control, like many other control schemes, are used in chemical control to improve the efficiency of chemical addition or control. By properly tuning the control loop that controls chemical addition, only the amount of chemical that is truly required is added to the system, saving money. The savings can be substantial when compared to a system which may be simply adding chemical at a constant rate to maintain some minimal addition under even the worst case conditions. The PID output controller is highly advantageous over simple control schemes that just utilize direct (proportional only) 4-20 mA output connections for control, since the PID controller can automatically adjust the “rate” of recovery based on the error between the setpoint and the measured value – which can be a substantial efficiency improvement..

The PID controller is basically designed to provide a “servo” action on the 4-20 mA output to control a process. If the user requires that a measured process stay as close as possible to a specific setpoint value, the controller output will change from 0% to 100% in an effort to keep the process at the setpoint. To affect this control, the controller must be used with properly selected control elements (valves, proper chemicals, etc.) that enable the controller to add or subtract chemical rapidly enough. This is not only specific to pumps and valves, but also to line sizes, delays in the system, etc.

This section is included to give a brief description of tuning details for the PID controller and is not intended to be an exhaustive analysis of the complexities of PID loop tuning. Numerous sources are available for specialized methods of tuning that are appropriate for a specific application.

## 7.2 PID Algorithm

As most users of PID controllers realize, the terminology for the actual algorithm terms and even the algorithms themselves can vary between different manufacturers. This is important to recognize as early as possible, since just plugging in similar values from one controller into another can result in dramatically different results. There are various basic forms of PID algorithms that are commonly seen, and the implementation here is the most common version; The ISA algorithm (commonly referred to as the “ideal” algorithm.)

$$output = P \left[ e(t) + \frac{1}{I} \int e(t) dt + D \frac{de(t)}{dt} \right]$$

Where:

Output =	controller output
P =	proportional gain
I =	integral gain
D =	derivative gain
t =	time
e(t) =	controller error (e=measured variable – setpoint)

**Figure 24 - Q46 ISA PID Equation**

The most notable feature of the algorithm is the fact the proportional gain term affects all components directly (unlike some other algorithms - like the “series” form.) If a pre-existing controller utilizes the same form of the algorithm shown above, it is likely similar settings can be made if the units on the settings are exactly the same. Be careful of this, as many times the units are the reciprocals of each other (i.e. reps-per-min, sec-per-rep.)

PID stands for “proportional, integral, derivative.” These terms describe the three elements of the complete controller action, and each contributes a specific reaction in the control process. The PID controller is designed to be primarily used in a “closed-loop” control scheme, where the output of the controller directly affects the input through some control device, such as a pump, valve, etc.

Although the three components of the PID are described in the setting area (section 6.25), here are more general descriptions of what each of the PID elements contribute to the overall action of the controller.

- P Proportional gain. With no “I” or “D” contribution, the controller output is simply a factor of the proportional gain multiplied by the input error (difference between the measured input and the controller setpoint.) Because a typical chemical control loop cannot react instantaneously to a correction signal, proportional gain is typically not efficient by itself – it must be combined with some integral action to be useful. Set the P term to a number between 2-4 to start. Higher numbers will cause the controller action to be quicker.
- I Integral gain. Integral gain is what allows the controller to eventually drive the input error to zero – providing accuracy to the control loop. It must be used to affect the accuracy in the servo action of the controller. Like proportional gain, increasing integral gain results in the control action happening quicker. Set the I term to a number between 3-5 to start (1-2 more than P). Like proportional gain, increasing the integral term will cause the controller action to be quicker.
- D Derivative gain. The addition of derivative control can be problematic in many applications, because it greatly contributes to oscillatory behavior. In inherently slow chemical control processes, differential control is generally added in very small amounts to suppress erratic actions in the process that are non-continuous, such as pumps and valves clicking on and off. However, as a starting point for chemical process control, its best to leave the “D” term set to 0.

Based on these descriptions, the focus on tuning for chemical applications really only involves adjustment of “P” and “I” in most cases. However, increasing both increases the response of the controller. The difference is in the time of recovery. Although combinations of high “P’s” and low “I” will appear to operate the same as combinations of low “P’s” and high “I’s”, there will be a difference in rate of recovery and stability. Because of the way the algorithm is structured, large “P’s” can have a larger impact to instability, because the proportional gain term impacts all the other terms directly. Therefore, keep proportional gain lower to start and increase integral gain to achieve the effect required.

Many of the classical tuning techniques have the user start with all values at 0, and then increase the P term until oscillations occur. The P value is then reduced to  $\frac{1}{2}$  of the oscillatory value, and the I term is increased to give the desired response. This can be done with the Q46F controller, with the exception that the I term should start no lower than 1.0.

If it appears that even large amounts of integral gain (>20) don’t appreciably increase the desired response, drop I back to about 1.0, and increase P by 1.00, and start increasing I again. In most chemical control schemes, I will be approximately 3 times the value of P.

### 7.3 Classical PID Tuning

Unlike many high speed position applications where PID loops are commonly used, the chemical feed application employed by this instrument does not require intense mathematical exercise to determine tuning parameters for the PID. In fact, the risk of instability is far greater with overly tuned PID control schemes. In addition, many of the classical mathematical exercises can be damaging or wasteful in the use of chemicals when the process is bumped with large amounts of input error to seek a response curve. Because of this, the general adjustment guidelines described in section 7.2 are sufficient for almost all application tuning for this instrument. Beyond this, many sources are available for classical tuning methods.

### 7.4 Manual PID Override Control

The Q46 PID output function allows the user to take manual control of the PID control signal. This is often useful when starting up a control loop, or in the event that you wish to bump the system manually to measure system response time.

To access the manual PID control, you must be in the MEASURE mode of operation and you must have the PID output displayed on the lower line. This line will indicate "XX.X% XX.X mA" with the X values simply indicating the current values. With this display on the screen, press and hold the ENTER key for about 5 seconds. You will see a small "m" show up between the % value and the mA value. This indicates you are now in manual mode.

Once in manual, you may increase the PID output by pressing the UP arrow or you may decrease the output by pressing the LEFT arrow. This will allow you to drive the PID output to any desired setting.

To revert to normal PID control, press and hold the ENTER key again until the "m" indicator disappears.

### 7.5 Common PID Pitfalls

The most common problem occurring in PID control applications involves the false belief that proper settings on only the PID controller can balance any process to an efficient level.

Close-loop control can only be effective if all elements in the loop are properly selected for the application, and the process behavior is properly understood. Luckily, the nature of simple chemical control process' are generally slow in nature. Therefore, even a de-tuned controller (one that responds somewhat slowly) can still provide substantial improvements to setpoint control. In fact, damaging oscillatory behavior is far more likely in tightly tuned controllers where the user attempted to increase response too much.

When deciding on a PID control scheme, it is important to initially review all elements of the process. Sticking valves, undersized pumps, or delays in reaction times associated with chemical addition can have a dramatic effect on the stability of the control loop. When controlling a chemical mix or reaction, the sensor should be placed in a location that ensures proper mixing or reaction time has occurred.

The easiest process' to control with closed-loop schemes are generally linear, and symmetrical, in nature. For example, controlling level in tank where the opening of valve for a fixed period of time corresponds linearly to the amount that flows into a tank. Chemical control process' can be more problematic when the nature of the setpoint value is non-linear relative to the input of chemical added. For example, pH control of a process may appear linear only in a certain range of operation and become highly exponential at the extreme ranges of the measuring scale. In

addition, if a chemical process is not symmetrical, that means it responds differentially to the addition and subtraction of chemical. It is important in these applications to study steady-state impact as well as step-change impact to process changes. In other words, once the process has apparently been tuned under normal operating conditions, the user should attempt to force a dramatic change to the input to study how the output reacts. If this is difficult to do with the actual process input (the recommended method), the user can place the control in manual at an extreme control point such as 5% or 95% and release it in manual. The recovery should not be overly oscillatory. If so, the loop needs to be de-tuned to deal with that condition (reduce P and/or I.)

# Part 8 – System Maintenance

---

## 8.1 General

The Q46TN Auto-Chem Total Ammonia System requires regular maintenance for reliable operation. Keep in mind that preventive maintenance on a regular schedule is much less troublesome than emergency maintenance that always seems to come at the wrong time.

## 8.2 Analyzer Maintenance

No maintenance of the electronic monitor is required if installed according to the guidelines of this operating manual. During operation, it is best to use only your finger to operate front panel keys. Using tools, especially sharp objects, to press front panel keys will result in damage to the panel keys.

## 8.3 Sensor Maintenance

The primary maintenance for a free ammonia system is periodic replacement of reagents and periodic service of both the ammonia sensor.

1. Replace reagents every 25 days if 1 gallon containers are used. Be sure to maintain supplies of reagent A buffer and reagent C stabilizer so that fresh reagents can be mixed before running out during operation.
2. Replace sensor membrane and electrolyte every 60-90 days. The frequency will vary depending on the quality of the water being measured.
3. Replace sample and reagent pump tubing every 6 months.

The procedure for mixing reagents is found earlier in this manual. The procedure for replacing sensor membranes and electrolyte is the same as is covered in the sensor preparation section.

The procedure for changing pump tubing is covered in the following pages.

## 8.4 Sample Pump Tube Replacement

Peristaltic pump tubing replacement is the most common maintenance required for the Auto-Chem system. The sample pump used in this system contains two different tubes, one for the inlet (left) side of the pump and one for the outlet (right) side of the pump. **These tubes MUST be installed in the proper location or the system will not work.**

The inlet tube has a slightly smaller I.D. than the outlet tube. This is necessary to ensure that the air stripping chamber does not fill with sample and force sample through the rest of the system.

**Both inlet and outlet tubes are black.** One spare tube of each size is provided in the spare parts kit. Spare tubing is available in packages of 5, and spare tubes are cut to the proper length at the factory. Be very careful to ensure that the I.D. of the tube used on the outlet is larger than the I.D. of the inlet tube. The difference is clear when comparing the two tubes side-by-side. Reversing the tube sizes on the pump will result in sample water being pumped through the parts of the system that should only see gas. **Also note that the tube fittings on the inlet side are smaller than those on the outlet side. The spare parts kit contains 2 of each size.**

To replace the sample pump tubing, follow these steps.

1. Remove the reagent pickup assembly from the reagent bottle and place it in a container of tap water. Allow the monitor to run for 30 minutes. This will ensure that all the buffer is out of the system prior to maintenance.
2. Release the front panel latch and tilt the front panel forward. Raise the lever on the fuse holder to turn off power to the chemistry system. Then, return the front panel to normal position.

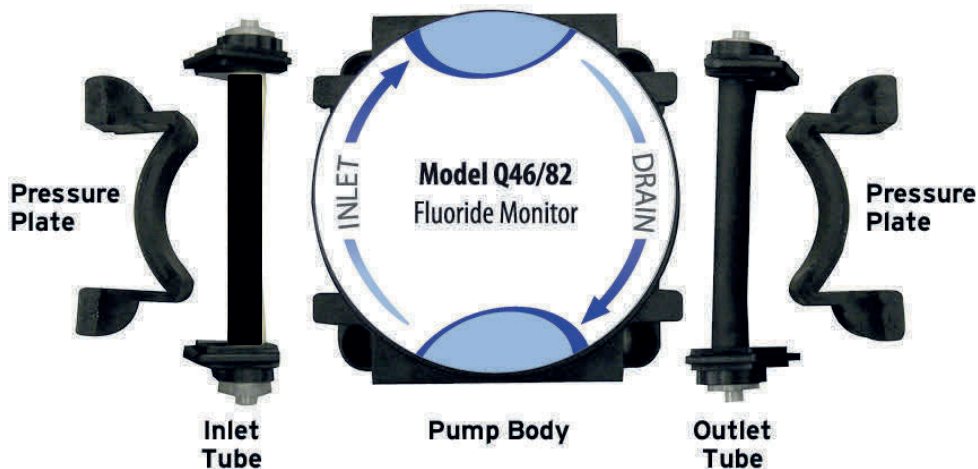

**Figure 25 – Sample Pump Exploded View**

3. Release the pressure plates on each side of the pump. This will allow sample and drain tubes to drain into the overflow. Then disconnect the inlet and outlet tubing connections from both sides of the pump.
4. Slide the tube holders out of the pump body and then pull the old tubes from barb end of the luer fittings.
5. Place one inlet tube and one outlet tube onto the proper sized fittings. Place the tube holders with the inlet tube onto the left side of the pump and place the tube holders with the outlet tube on the right side.
6. Once tube holders are in place, replace the pressure plates on each side of the pump.

## 8.5 Reagent Pump Tube Replacement

Replacement of the reagent pump tubes is similar to the procedure used for the sample pump. However, the replacement reagent tubes are supplied with the plastic tube fittings already attached. Do not pull the microbore tubing off of the fittings as it is difficult to put back on.

The reagent tubing assemblies snap into the tube holders at the middle of the plastic tube fittings. Observe the position of these assemblies prior to removing the old ones.

# Part 9 – Troubleshooting

---

## 9.1 General

The information included in this section is intended to be used in an attempt to quickly resolve an operational problem with the system. During any troubleshooting process, it will save the most time if the operator can first determine if the problem is related to the analyzer, sensor, or some external source. Therefore, this section is organized from the approach of excluding any likely external sources, isolating the analyzer, and finally isolating the sensor. If these procedures still do not resolve the operational problems, any results the operator may have noted here will be very helpful when discussing the problem with the factory technical support group.

## 9.2 External Sources of Problems

To begin this process, review the connections of the system to all external connections.

1. Verify the analyzer is earth grounded. An earth ground connection **MUST** be present for the shielding systems in the electronics to be active. Grounded conduit provides no earth connection to the plastic enclosure, so an earth ground wiring connection must be made at the power input terminal strip.
2. Verify the proper power input is present (115/230 VAC).
3. Verify the loads on any 4-20 mA outputs do not exceed the limits in the Instrument Specifications. During troubleshooting, it is many times helpful to disconnect all these outputs and place wire-shorts across the terminals in the instrument to isolate the system and evaluate any problems which may be coming down the analog output connections.
4. Do not run sensor cables or analog output wiring in the same conduits as power wiring. If low voltage signal cables must come near power wiring, cross them at 90° to minimize coupling.
5. If rigid conduit has been run directly to the Q46 enclosure, check for signs that moisture has followed conduit into the enclosure.
6. Check for ground loops. Although the sensor is electrically isolated from the process, high frequency sources of electrical noise may still cause erratic behavior in extreme conditions.
7. On systems where relays are in use, check the relay load to verify the load is within the contact rating of the relays. Relay contacts which have been used for higher power AC current loads may become unsuitable for very low signal DC loads later on because a small amount of pitting can form on the contacts. If the load is highly inductive (solenoids, motor starters, large aux relays), note that the contact rating will be de-rated to a lower level. Also, due to the large amount of energy present in circuits driving these types of loads when they are switched on an off, the relay wiring placement can result in electrical interference for other devices. This can be quickly resolved by moving wiring, or by adding very inexpensive snubbers (such As Quencharcs) to the load.

### 9.3 Analyzer Tests

1. Disconnect power and completely disconnect all output wiring coming from the analyzer. Remove sensor wiring, relay wiring, and analog output wiring. Re-apply power to the analyzer.
2. Using the Simulate feature, check operation of analog outputs and relays with a DMM.
3. Check TC drive circuit. Place a wire-short between the GREEN and BLACK terminals. With a digital voltmeter (DVM), measure the voltage between the BLACK and RED terminals on the monitor to verify that the TC drive circuit is producing about 4.8-5.1 Vdc open circuit. Remove DVM completely and connect a 100 Ohm resistor from the BLACK to RED terminals. The temperature reading should display approximately 0°C.



## 9.4 Display Messages

The Q46 Series instruments provide a number of diagnostic messages which indicate problems during normal operation and calibration. These messages appear as prompts on the secondary line of the display or as items on the Fault List.

MESSAGE	DESCRIPTION	POSSIBLE CORRECTION
<b>Max is 200</b>	Entry failed, maximum user value allowed is 200.	Reduce value to $\leq 200$
<b>Min is 200</b>	Entry failed, minimum value allowed is 200.	Increase value to $\geq 200$
<b>Cal Unstable</b>	Calibration problem, data too unstable to calibrate. Icons will not stop flashing if data is too unstable. User can bypass by pressing ENTER.	Check to see that a stable standard is in use. If sample is stable, verify that sample from the drain tube is above pH 10. Replace sensor is necessary
<b>Out of Range</b>	Input value is outside selected range of the specific list item being configured.	Check manual for limits of the function to be configured.
<b>Locked!</b>	Transmitter security setting is locked.	Enter security code to allow modifications to settings.
<b>Unlocked!</b>	Transmitter security has just been unlocked.	Displayed just after security code has been entered.
<b>Offset High</b>	The sensor zero offset point is out of the acceptable range.	Check wiring connections to sensor. Allow sensor to operate powered a minimum of 1 hour prior to first cal.
<b>Sensor High</b>	The raw signal from the sensor is too high and out of instrument range.	Check wiring connections to sensor. Be sure that the blue and white wires are not reversed.
<b>Sensor Low</b>	The raw signal from the sensor is too low.	Check wiring connections to sensor.
<b>NH3 High</b>	The ammonia reading is greater than the maximum of the User-selected range.	The reading is over operating limits. Set measuring range to the next highest level.
<b>Cal Fail</b>	Failure of total ammonia or monochloramine calibration. FAIL icon will not extinguish until successful calibration has been performed, or 30 minutes passes with no keys being pressed.	Clean sensor redo calibration. Check calibration standards to be sure they are correct. Check reagent supply. Inspect to ensure that both reagent A and B are being injected properly.
<b>EPROM Fail</b>	Internal nonvolatile memory failure	System failure, consult factory.
<b>Chcksum Fail</b>	Internal software storage error.	System failure, consult factory.
<b>Display Fail</b>	Internal display driver fail.	System failure, consult factory.
<b>Range Cal Fail</b>	Failure of factory temperature calibration.	Consult factory.

**Figure 26 - Q46 Display Messages**

# Spare Parts

---

<u>Part No.</u>	<u>Description</u>
-----------------	--------------------

## **Q46 Electronic Assembly**

03-0392	Q46N front lid assembly
07-0316	Q46FN 100-240 VAC monitor assembly
07-0318	Q46FN 100-240 VAC monitor assembly with Profibus
03-0409	P/S Assy, 100-240 VAC with 3 relay exp. Board
23-0029	Fuse, 630mA, 250V, TR-5
38-0072	Terminal block plug, 3 position (relays)
38-0073	Terminal block plug, 4 position (outputs)
38-0074	Terminal block plug, 3 position (ground)
38-0081	Terminal block plug, 3 position (power)
38-0084	Terminal block plug, 3 position (power) – VDC version*

**\*NOTE: prior to Dec 2018, VDC (power) Terminal block used the (38-0081)**

44-0311	Conduit entry plug, red PE
44-0274	Cord grip, ½" NPT

## **Sensors and Sensor Parts**

00-1693	B10-68 Total Ammonia Sensor
00-1694	C10-63 Combined Chlorine Sensor
05-0023	Combined chlorine membranes, pkg. of 10
05-0075	Total ammonia sensor membranes, pkg of 10
09-0056	Sensor electrolyte, 120 ml.
05-0004	Sensor O-ring kit

## **Auto-Chem Assembly**

00-1495	Monochloramine sensor preamp
00-1652	12 VAC Power Supply, 120 VAC input
00-1657	12 VAC Power Supply, 230 VAC input
31-0177	Sensor cable with connector, 18"
60-0058	Temperature Controller
03-0450	Standards Feed Tube Assy
03-0475	Sample temperature control block with RTD - Titanium
54-0039	Heater for 03-0475
28-0033	12 VDC Power Supply, 4.5A
23-0002	Fuse, 2 A
03-0421	Sample pump assembly (requires parameter label)
03-0422	Reagent pump assembly
36-0051	Sample pump motor, 24 RPM
36-0049	Reagent pump motor, 6 RPM
03-0427	Pump motor wiring harness
05-0103	Sample pump inlet tubing, pkg. of 5
05-0104	Sample pump drain tubing, pkg. of 5
05-0102	Reagent pump tubing assembly, pkg. of 10
45-0323	Total Ammonia sensor flowcell
42-0014	Total Ammonia sensor flowcell O-Ring
31-0027	9-Conductor shielded cable

### **Tubing Fittings**

44-0009	1/8" NPT x 1/4" I.D. barb fitting (inlet)
44-0010	3/8" NPT x 1/2" I.D. barb fitting (drain)
44-0363	1/4 - 28 x 1/8" I.D. right angle barb fitting
44-0115	Injection tee for reagent B
44-0159	Luer fitting, female, 1/8" barb
44-0164	Luer fitting, male, 1/8" barb
44-0167	1/8" NPT x 1/8" I.D. barb fitting
44-0184	Luer adapter, 1/8" NPT x male luer
44-0253	Luer adapter, female, panel mount, 1/4-28 x 1/8" barb
44-0275	Injection tee for reagents A and C
44-0325	Check valve
44-0348	Luer adapter, 5/32" tubing, sample pump inlet
44-0394	Luer adapter, 3/16" tubing, sample pump outlet
44-0354	Luer tee fitting

### **Tubing**

44-0007	Silicone tubing, 1/8" I.D. x 1/4" O.D.
44-0193	Silicone tubing, 1/16" I.D., opaque
44-0344	Silicone tubing, 1/16" I.D., blue
44-0345	Silicone tubing, 1/16" I.D., red

### **Reagents**

09-0074	Ammonia Reagent A Buffer
09-0075	Ammonia Reagent C
51-0066	Hydrogen Peroxide, 27% (drop ship item)

**Lock/Unlock Code: 1462**

# PRODUCT WARRANTY

Analytical Technology, Inc. (Manufacturer) warrants to the Customer that if any part(s) of the Manufacturer's equipment proves to be defective in materials or workmanship within the earlier of 18 months of the date of shipment or 12 months of the date of start-up, such defective parts will be repaired or replaced free of charge. Inspection and repairs to products thought to be defective within the warranty period will be completed at the Manufacturer's facilities in Collegeville, PA. Products on which warranty repairs are required shall be shipped freight prepaid to the Manufacturer. The product(s) will be returned freight prepaid and allowed if it is determined by the manufacturer that the part(s) failed due to defective materials or workmanship.

This warranty does not cover consumable items, batteries, or wear items subject to periodic replacement including lamps and fuses.

Gas sensors carry a 12 month from date of shipment warranty and are subject to inspection for evidence of misuse, abuse, alteration, improper storage, or extended exposure to excessive gas concentrations. Should inspection indicate that sensors have failed due to any of the above, the warranty shall not apply.

The Manufacturer assumes no liability for consequential damages of any kind, and the buyer by acceptance of this equipment will assume all liability for the consequences of its use or misuse by the Customer, his employees, or others. A defect within the meaning of this warranty is any part of any piece of a Manufacturer's product which shall, when such part is capable of being renewed, repaired, or replaced, operate to condemn such piece of equipment.

This warranty is in lieu of all other warranties (including without limiting the generality of the foregoing warranties of merchantability and fitness for a particular purpose), guarantees, obligations or liabilities expressed or implied by the Manufacturer or its representatives and by statute or rule of law.

This warranty is void if the Manufacturer's product(s) has been subject to misuse or abuse or has not been operated or stored in accordance with instructions, or if the serial number has been removed.

Analytical Technology, Inc. makes no other warranty expressed or implied except as stated above.



## WATER QUALITY MONITORS

Dissolved Oxygen  
Free Chlorine  
Combined Chlorine  
Total Chlorine  
Residual Chlorine Dioxide  
Potassium Permanganate  
Dissolved Ozone  
pH/ORP  
Conductivity  
Hydrogen Peroxide  
Peracetic Acid  
Dissolved Sulfide  
Residual Sulfite  
Fluoride  
Dissolved Ammonia  
Turbidity  
Suspended Solids  
Sludge Blanket Level  
MetriNet Distribution Monitor

## GAS DETECTION PRODUCTS

NH <sub>3</sub>	Ammonia
CO	Carbon Monoxide
H <sub>2</sub>	Hydrogen
NO	Nitric Oxide
O <sub>2</sub>	Oxygen
CO	Cl <sub>2</sub> Phosgene
Br <sub>2</sub>	Bromine
Cl <sub>2</sub>	Chlorine
ClO <sub>2</sub>	Chlorine Dioxide
F <sub>2</sub>	Fluorine
I <sub>2</sub>	Iodine
H <sub>x</sub>	Acid Gases
C <sub>2</sub> H <sub>4</sub> O	Ethylene Oxide
C <sub>2</sub> H <sub>6</sub> O	Alcohol
O <sub>3</sub>	Ozone
CH <sub>4</sub>	Methane (Combustible Gas)
H <sub>2</sub> O <sub>2</sub>	Hydrogen Peroxide
HCl	Hydrogen Chloride
HCN	Hydrogen Cyanide
HF	Hydrogen Fluoride
H <sub>2</sub> S	Hydrogen Sulfide
NO <sub>2</sub>	Nitrogen Dioxide
NO <sub>x</sub>	Oxides of Nitrogen
SO <sub>2</sub>	Sulfur Dioxide
H <sub>2</sub> Se	Hydrogen Selenide
B <sub>2</sub> H <sub>6</sub>	Diborane
GeH <sub>4</sub>	Germane
AsH <sub>3</sub>	Arsine
PH <sub>3</sub>	Phosphine
SiH <sub>4</sub>	Silane
HCHO	Formaldehyde
C <sub>2</sub> H <sub>4</sub> O <sub>3</sub>	Peracetic Acid
DMA	Dimethylamine